

User Guide

FIERY XJ BP100

ELECTRONICS FOR IMAGING, INC.



Copyright © 1998 Electronics for Imaging, Inc. All rights reserved.

This publication is protected by copyright, and all rights are reserved. No part of it may be reproduced or transmitted in any form or by any means for any purpose without express prior written consent from Electronics for Imaging, Inc., except as expressly permitted herein. Information in this document is subject to change without notice and does not represent a commitment on the part of Electronics for Imaging, Inc.

The software described in this publication is furnished under license and may only be used or copied in accordance with the terms of such license.

Patents: 5,666,436; 5,553,200; 5,543,940; 5,537,516; 5,517,334; 5,506,946; 5,424,754; 5,343,311; 5,212,546; 4,941,038; 4,837,722; 4,500,919

Trademarks

EFI, the EFI logo, Fiery, the Fiery logo, EFICOLOR, and Rip-While-Print are trademarks registered in the U.S. Patent and Trademark Office. Fiery XJ, Fiery ZX, Fiery X2, Fiery Driven, the Fiery Driven logo, Command WorkStation, AutoCal, Starr Compression, Memory Multiplier, ColorWise, NetWise, and VisualCal are trademarks of Electronics for Imaging, Inc.

Adobe, the Adobe logo, Adobe Illustrator, PostScript, Adobe Photoshop, Adobe Separator, and Adobe PageMaker are trademarks of Adobe Systems Incorporated, registered in certain jurisdictions. EPS (Encapsulated PostScript) is a trademark of Altsys Corporation. Apple, the Apple logo, AppleShare, AppleTalk, EtherTalk, LaserWriter, and Macintosh are registered trademarks, and MultiFinder is a trademark of Apple Computer, Inc. Microsoft, MS, MS-DOS, and Windows are registered trademarks of Microsoft in the US and other countries. QuarkXPress is a registered trademark of Quark, Inc. Times, Helvetica, and Palatino are trademarks of Linotype AG and/or its subsidiaries. ITC Avant Garde, ITC Bookman, ITC Zapf Chancery, and ITC Zapf Dingbats are registered trademarks of International Typeface Corporation. Ethernet is a registered trademark of Xerox Corporation. Farallon, PhoneNET PC, and PhoneNET Talk are trademarks of Farallon Computing, Inc. COPS and COPSTalk are trademarks of CoOperative Printing Solutions, Inc. NetWare and Novell are registered trademarks and Internetwork Packet Exchange (IPX) is a trademark of Novell, Inc. SyQuest is a registered trademark, in the United States and certain other countries, of SyQuest Technology, Inc. UNIX is a registered trademark of UNIX System Laboratories, a wholly owned subsidiary of Novell, Inc.

All other terms and product names may be trademarks or registered trademarks of their respective owners, and are hereby acknowledged.

Legal Notices

APPLE COMPUTER, INC. ("APPLE") MAKES NO WARRANTIES, EXPRESS OR IMPLIED, INCLUDING WITHOUT LIMITATION THE IMPLIED WARRANTIES OF MERCHANTABILITY AND FITNESS FOR A PARTICULAR PURPOSE, REGARDING THE APPLE SOFTWARE. APPLE DOES NOT WARRANT, GUARANTEE, OR MAKE ANY REPRESENTATIONS REGARDING THE USE OR THE RESULTS OF THE USE OF THE APPLE SOFTWARE IN TERMS OF ITS CORRECTNESS, ACCURACY, RELIABILITY, CURRENTNESS, OR OTHERWISE. THE ENTIRE RISK AS TO THE RESULTS AND PERFORMANCE OF THE APPLE SOFTWARE IS ASSUMED BY YOU. THE EXCLUSION OF IMPLIED WARRANTIES IS NOT PERMITTED BY SOME STATES. THE ABOVE EXCLUSION MAY NOT APPLY TO YOU.

IN NO EVENT WILL APPLE, ITS DIRECTORS, OFFICERS, EMPLOYEES OR AGENTS BE LIABLE TO YOU FOR ANY CONSEQUENTIAL, INCIDENTAL OR INDIRECT DAMAGES (INCLUDING DAMAGES FOR LOSS OF BUSINESS PROFITS, BUSINESS INTERRUPTION, LOSS OF BUSINESS INFORMATION, AND THE LIKE) ARISING OUT OF THE USE OR INABILITY TO USE THE APPLE SOFTWARE EVEN IF APPLE HAS BEEN ADVISED OF THE POSSIBILITY OF SUCH DAMAGES. BECAUSE SOME STATES DO NOT ALLOW THE EXCLUSION OR LIMITATION OF LIABILITY FOR CONSEQUENTIAL OR INCIDENTAL DAMAGES, THE ABOVE LIMITATIONS MAY NOT APPLY TO YOU.

Apple's liability to you for actual damages from any cause whatsoever, and regardless of the form of the action (whether in contract, tort [including negligence], product liability or otherwise), will be limited to \$50.

Restricted Rights Legends

For defense agencies: Restricted Rights Legend. Use, reproduction, or disclosure is subject to restrictions set forth in subparagraph (c)(1)(ii) of the Rights in Technical Data and Computer Software clause at 252.227.7013.

For civilian agencies: Restricted Rights Legend. Use, reproduction, or disclosure is subject to restrictions set forth in subparagraph (a) through (d) of the commercial Computer Software Restricted Rights clause at 52.227-19 and the limitations set forth in Electronics for Imaging, Inc.'s standard commercial agreement for this software. Unpublished rights reserved under the copyright laws of the United States.

Printed in the United States of America on recycled paper.

Part Number: 45000218

FCC Information

WARNING: FCC Regulations state that any unauthorized changes or modifications to this equipment not expressly approved by the manufacturer could void the user's authority to operate this equipment.

Class B Declaration of Conformity

This equipment has been tested and found to comply with the limits for a class B digital device, pursuant to Part 15 of the FCC rules. These limits are designed to provide reasonable protection against harmful interference in a residential installation. This equipment generates, uses and can radiate radio frequency energy and if not installed and used in accordance with the instructions, may cause harmful interference to radio communications. However, there is no guarantee that interference will not occur in a particular installation.

If this equipment does cause harmful interference to radio or television reception, which can be determined by turning the equipment off and on, the user is encouraged to try to correct the interference by one or more of the following measures:

Reorient or relocate the receiving antenna.

Increase the separation between the equipment and receiver.

Connect the equipment into an outlet on a circuit different from that to which the receiver is connected.

Consult the dealer or an experienced radio/TV technician for help.

In order to maintain compliance with FCC regulations, shielded cables must be used with this equipment. Operation with non-approved equipment or unshielded cables is likely to result in interference to radio and TV reception. The user is cautioned that changes and modifications made to the equipment without the approval of manufacturer could void the user's authority to operate this equipment.

Industry Canada Class B Notice

This Class B digital apparatus meets all the requirements of the Canadian Interference-Causing Equipment Regulations.

Avis de Conformité Classe B de l'Industrie Canada

Cet appareil numérique de la classe B respecte toutes les exigences du Règlement sur le matériel brouilleur du Canada.

Certificate by Manufacturer/Importer

This is to certify that the FC07 is shielded against radio interference in accordance with the provisions of VFG 243/1991. The German Postal Services have been advised that this device is being put on the market and that they have been given the right to inspect the series for compliance with the regulations. Electronics for Imaging, Inc.

Bescheinigung des Herstellers/Importeurs

Heirmit wird bescheinigt, dass der FC07 im Uebereinstimmung mit den Bestimmungen der VFG 243/1991 Funk-Entstort ist. Der Deutschen Bundespost wurde das Inverkehrbringen dieses Geraetes angezeigt und die Berechtigung zur Ueberpruefung der Serie auf Einhaltung der Bestimmungen eingeraumt. Electronics for Imaging, Inc.

RFI Compliance Notice

This equipment has been tested concerning compliance with the relevant RFI protection requirements both individually and on system level (to simulate normal operation conditions). However, it is possible that these RFI Requirements are not met under certain unfavorable conditions in other installations. It is the user who is responsible for compliance of his particular installation.

Dieses Geraet wurde einzeln sowohl als auch in einer Anlage, die einen normalen Anwendungsfall nachbildet, auf die Einhaltung der Funk-entstoerbestimmungen geprueft. Es ist jedoch moeglich, dass die Funk-entstoerbestimmungen unter unguenstigen Umstaenden bei anderen Geraetekombinationen nicht eingehalten werden. Fuer die Einhaltung der Funk-entstoerbestimmungen seigner gesamten Anlage, in der dieses Geraet betrieben wird, ist der Betreiber verantwortlich.

Compliance with applicable regulations depends on the use of shielded cables. It is the user who is responsible for procuring the appropriate cables.

Einhaltung mit betreffenden Bestimmungen kommt darauf an, dass geschirmte Ausfuehrungen gebraucht werden. Fuer die beschaffung richtiger Ausfuehrungen ist der Betreiber verantwortlich.

Software License Agreement

Before using the Software, please carefully read the following terms and conditions. BY USING THIS SOFTWARE, YOU SIGNIFY THAT YOU HAVE ACCEPTED THE TERMS OF THIS AGREEMENT. If you cannot or do not accept these terms, you may return the entire package within ten (10) days to the Distributor or Dealer from which you obtained them for a full refund.

Electronics for Imaging, Inc. grants to you a non-exclusive, non-transferable license to use the software and accompanying documentation ("Software") included with the Fiery XJ you have purchased, including without limitation the PostScript® software provided by Adobe Systems Incorporated.

You may:

- a. use the Software solely for your own customary business purposes and solely with Fiery XJ;
- b. use the digitally-encoded machine-readable outline and bitmap programs ("Font Programs") provided with Fiery XJ in a special encrypted format ("Coded Font Programs") to reproduce and display designs, styles, weights, and versions of letters, numerals, characters and symbols ("Typefaces") solely for your own customary business purposes on the display window of the Fiery XJ or monitor used with Fiery XJ;
- c. use the trademarks used by Electronics for Imaging to identify the Coded Font Programs and Typefaces reproduced therefrom ("Trademarks"); and
- d. assign your rights under this Agreement to a transferee of all of your right, title and interest in and to Fiery XJ provided the transferee agrees to be bound by all of the terms and conditions of this Agreement.

You may not:

- a. make use of the Software, directly or indirectly, to print bitmap images with print resolutions of 600 dots per inch or greater, or to generate fonts or typefaces for use other than with Fiery XJ;
- b. make or have made, or permit to be made, any copies of the Software, Coded Font Programs, accompanying documentation or portions thereof, except as necessary for use with the Fiery XJ unit purchased by you; provided, however, that under no circumstances may you make or have made, or permit to be made, any copies of that certain portion of the Software which has been included on the Fiery XJ hard disk drive. You may not copy the documentation;
- c. attempt to alter, disassemble, decrypt or reverse engineer the Software, Coded Font Programs or accompanying documentation.
- d. rent or lease the Software.

Proprietary Rights

You acknowledge that the Software, Coded Font Programs, Typefaces, Trademarks and accompanying documentation are proprietary to Electronics for Imaging and its suppliers and that title and other intellectual property rights therein remain with Electronics for Imaging and its suppliers. Except as stated above, this Agreement does not grant you any right to patents, copyrights, trade secrets, trademarks (whether registered or unregistered), or any other rights, franchises or licenses in respect of the Software, Coded Font Programs, Typefaces, Trademarks or accompanying documentation. You may not adapt or use any trademark or trade name which is likely to be similar to or confusing with that of Electronics for Imaging or any of its suppliers or take any other action which impairs or reduces the trademark rights of Electronics for Imaging or its suppliers. The trademarks may only be used to identify printed output produced by the Coded Font Programs. At the reasonable request of Electronics for Imaging, you must supply samples of any Typeface identified with a trademark.

Confidentiality

You agree to hold the Software and Coded Font Programs in confidence, disclosing the Software and Coded Font Programs only to authorized users having a need to use the Software and Coded Font Programs as permitted by this Agreement and to take all reasonable precautions to prevent disclosure to other parties.

Remedies

Unauthorized use, copying or disclosure of the Software, Coded Font Programs, Typefaces, Trademarks or accompanying documentation will result in automatic termination of this license and will make available to Electronics for Imaging other legal remedies.

Limited Warranty And Disclaimer

Electronics for Imaging warrants that, for a period of ninety (90) days from the date of delivery to you, the Software under normal use will perform without significant errors that make it unusable. Electronics for Imaging's entire liability and your exclusive remedy under this warranty (which is subject to you returning Fiery XJ to Electronics for Imaging or an authorized dealer) will be, at Electronics for Imaging's option, to use reasonable commercial efforts to attempt to correct or work around errors, to replace the Software with functionally equivalent software, or to refund the purchase price and terminate this Agreement. Some states do not allow limitations on duration of implied warranty, so the above limitation may not apply to you.

Except for the above express limited warranty, Electronics for Imaging makes and you receive no warranties or conditions on the Products, express, implied, or statutory, and Electronics for Imaging specifically disclaims any implied warranty or condition of merchantability or fitness for a particular purpose.

For warranty service, please contact your authorized service/support center.

EXCEPT FOR THE ABOVE EXPRESS LIMITED WARRANTY, ELECTRONICS FOR IMAGING MAKES AND YOU RECEIVE NO WARRANTIES OR CONDITIONS ON THE SOFTWARE OR CODED FONT PROGRAMS, EXPRESS, IMPLIED, STATUTORY, OR IN ANY OTHER PROVISION OF THIS AGREEMENT OR COMMUNICATION WITH YOU, AND ELECTRONICS FOR IMAGING SPECIFICALLY DISCLAIMS ANY IMPLIED WARRANTY OR CONDITION OF MERCHANTABILITY OR FITNESS FOR A PARTICULAR PURPOSE. Electronics for Imaging does not warrant that the operation of the software will be uninterrupted or error free or that the Software will meet your specific requirements.

Limitation Of Liability

IN NO EVENT WILL ELECTRONICS FOR IMAGING OR ITS SUPPLIERS BE LIABLE FOR ANY DAMAGES, INCLUDING LOSS OF DATA, LOST PROFITS, COST OF COVER OR OTHER SPECIAL, INCIDENTAL, CONSEQUENTIAL OR INDIRECT DAMAGES ARISING FROM THE USE OF THE SOFTWARE, CODED FONT PROGRAMS OR ACCOMPANYING DOCUMENTATION, HOWEVER CAUSED AND ON ANY THEORY OF LIABILITY. THIS LIMITATION WILL APPLY EVEN IF ELECTRONICS FOR IMAGING OR ANY AUTHORIZED DEALER HAS BEEN ADVISED OF THE POSSIBILITY OF SUCH DAMAGE. YOU ACKNOWLEDGE THAT THE PRICE OF THE UNIT REFLECTS THIS ALLOCATION OF RISK. BECAUSE SOME STATES/JURISDICTIONS DO NOT ALLOW THE EXCLUSION OR LIMITATION OF LIABILITY FOR CONSEQUENTIAL OR INCIDENTAL DAMAGES, THE ABOVE LIMITATION MAY NOT APPLY TO YOU.

Export Controls

You agree that you will not export or re-export the Software or Coded Font Programs in any form without the appropriate United States and foreign government licenses. Your failure to comply with this provision is a material breach of this Agreement.

Government Use

Use, duplication or disclosure of the Software by the United States Government is subject to restrictions as set forth in subdivision (c) (1) (ii) of the Rights in Technical Data and Computer Software clause at DFARS 252.227-7013 or in subparagraphs (c) (1) and (2) of the Commercial Computer Software—Restricted Right Clause at 48 CFR 52.227-19, as applicable.

Third Party Beneficiary

You are hereby notified that Adobe Systems Incorporated, a California corporation located at 345 Park Avenue, San Jose, CA 95110-2704 (“Adobe”) is a third-party beneficiary to this Agreement to the extent that this Agreement contains provisions which relate to your use of the Fonts, the Coded Font Programs, the Typefaces and the Trademarks licensed hereby. Such provisions are made expressly for the benefit of Adobe and are enforceable by Adobe in addition to Electronics for Imaging.

General

This Agreement will be governed by the laws of the State of California.

This Agreement is the entire agreement held between us and supersedes any other communications or advertising with respect to the Software, Coded Font Programs and accompanying documentation.

If any provision of this Agreement is held invalid, the remainder of this Agreement shall continue in full force and effect.

If you have any questions concerning this Agreement, please write to Electronics for Imaging, Inc., Attn: Licensing Dept. or see Electronics for Imaging’s web site at www.efi.com.

Electronics for Imaging, Inc.
2855 Campus Drive
San Mateo, CA 94403

Contents

Preface

Copier support and media pack	xi
About the documentation	xii
About this manual	xii
Terminology and conventions	xiii
How the Fiery XJ works	xiii
About PostScript printer drivers and PPDs	xiv
Supported paper sizes	xiv
Fiery XJ job environments	xv
Permissions	xv
Before you begin	xvi

Chapter 1: Using the Control Panel

Introduction to the Fiery XJ Control Panel	1-1
Activity light	1-1
Buttons	1-2
Display window	1-2
Functions menu	1-4
Starting and shutting down the Fiery XJ	1-5
Starting the Fiery XJ	1-5
Restarting the Fiery XJ	1-6
Shutting down the Fiery XJ	1-7
Safety warnings	1-7
Cleaning the Fiery XJ	1-7

Chapter 2: Printing from Windows Computers

Printing from applications	2-1
Setting options and printing from Windows 95	2-1
Setting options and printing from Windows NT 4.0	2-6
Printing to the parallel port	2-8
Saving files to print at a remote location	2-8

Using Fiery Downloader to print	2-9
---------------------------------	-----

Chapter 3: Printing from Mac OS Computers

Printing from applications	3-1
Selecting the Fiery XJ in the Chooser	3-1
Setting print options and printing from Mac OS computers	3-2

Using Fiery Downloader to print	3-4
---------------------------------	-----

Chapter 4: Printing from UNIX Workstations

Printing to the Fiery XJ	4-1
--------------------------	-----

Chapter 5: Downloading Files and Fonts

Using Fiery Downloader	5-1
Printing with Fiery Downloader	5-3
Downloading and managing printer fonts	5-6

Chapter 6: Tracking and Managing Print Jobs

Tools for job tracking and management	6-1
Fiery WebTools	6-1
Fiery Spooler	6-1

About Fiery WebTools	6-2
Access privileges	6-2
Checking Fiery XJ status with the Status WebTool	6-4

Fiery WebSpooler and Fiery Spooler for Windows	6-5
Job management features	6-7
Job List window	6-8
Job icons	6-12
Job commands	6-14
Overriding print settings	6-15
Using the Job Log	6-16
Differences between Fiery WebSpooler and Fiery Spooler for Windows	6-18

Fiery Spooler for Mac OS computers	6-19
The job list	6-21
Duplicating, copying, moving, and deleting jobs	6-23
Changing print settings for a job	6-25
Using the Job Log	6-26

Chapter 7: Color Calibration

Introduction	7-1
---------------------	-----

Understanding calibration	7-1
How calibration works	7-2
Scheduling calibration	7-3
Checking calibration status	7-5

Calibrating with AutoCal from the Control Panel	7-5
Removing calibration	7-7

Working with simulations	7-7
Changing simulation targets	7-8

Appendix A: Print Options

Where to set print options	A-1
Print options and override hierarchy	A-2
More information about print options	A-3

Appendix B: Font List

Printer fonts	B-1
Adobe Type 1 fonts	B-1
TrueType fonts	B-5

Appendix C: Troubleshooting

Error messages	C-1
Maintaining optimal system performance	C-3
Troubleshooting	C-4
General printing problems	C-4
Problems with print quality	C-6
Problems with Fiery Downloader	C-7
Problems with Fiery WebTools	C-9
Setup error messages	C-9
AutoCal error messages	C-9

Index

Preface

The Fiery XJ BP100 enables you to use your color copier as a networked printer. You can use the Fiery XJ BP100 to print final documents or to proof jobs you will later print on an offset press. You send a print job to the Fiery XJ BP100 as you would to any other printer—you select it from the Printers dialog box on Windows computers, or in the Chooser on Mac OS computers—and then print from within any application.

NOTE: In this manual, the term “Fiery XJ” is used to refer to the Fiery XJ BP100.

Users with the necessary access privileges can monitor and manage jobs sent to the Fiery XJ and perform color calibration of the color server using AutoCal. Additionally, with Fiery XJ user software, you can also download files and fonts to the Fiery XJ.

Copier support and media pack

The Fiery XJ supports R2 color copiers—the term “copier” refers to the following models:

- Ricoh Aficio Color 5106 and 5206
- Lanier 5606DC
- Sharp AR-C861 and AR-C862
- Gestetner 2606 and 2606e
- nashuatec C606 and C606e
- Rex Rotary CC8606 and CC8606E
- infotec 7316 and 7316E
- Savin SDC206 and SDC206E

Your Fiery XJ includes a media pack containing:

- User Software CD
- Documentation set

About the documentation

This manual is part of a set of Fiery XJ documentation that includes the following manuals for users and system administrators:

- The *Administrator Guide* explains basic configuration and administration of the Fiery XJ for the supported platforms and network environments. It also includes guidelines for setting up UNIX, Windows NT, and Novell NetWare servers to provide Adobe PostScript printing services to clients.
- *Getting Started* describes how to install software to enable users to print to the Fiery XJ. Specifically, it describes installation of PostScript™ printer drivers, printer description files, and other user software provided on the Fiery XJ User Software CD. It also explains how to connect each user to the network.
- The *User Guide* describes the printing features of the Fiery XJ for users who send jobs via remote workstations on the network or via a direct parallel port connection. It also explains the functions of the Fiery WebTools and Fiery XJ client utilities and how they can be used to manage jobs, and provides troubleshooting information for problems that may arise.
- *Release Notes* provide last-minute product information and workarounds for some of the problems you may encounter.

About this manual

This manual covers the following topics:

- Using the Fiery XJ Control Panel
- Printing from Windows computers
- Printing from Mac OS computers
- Printing from UNIX® workstations
- Downloading files and fonts using Fiery Downloader
- Tracking and managing jobs and accessing information using Fiery WebTools™ and Fiery client utilities
- Calibrating the Fiery XJ with AutoCal™
- Specifying and overriding job settings, the printer fonts installed on the Fiery XJ, and troubleshooting information

Terminology and conventions

Specific terms are explained as they are introduced. However, the following general terms are used throughout:

- **PostScript (PS)**—A computer language designed as a page description language. The Fiery XJ uses this language for imaging the page and for communication with applications and with the print engine.
- **Job**—A file consisting of PostScript commands and comments that describe the graphics, sampled images, and text that should appear on each page of a document, and the printer options that should be used in printing, such as media or color rendering style.
- **Spool**—Write to a disk. Usually used here to refer to a PostScript print job being saved to the Fiery XJ hard disk in preparation for processing and printing.
- **RIP**—Acronym for raster image processing, which changes text and graphics commands into descriptions of each mark on a page. In common use as a noun, a “raster image processor” (RIP) is the computer processor that performs this function.
- **Print**—The process of rendering, or imaging, a page or a job on a printer.

These concepts can explain how the Fiery XJ and the copier work together as a powerful printing system. The Fiery XJ PostScript RIP changes text and graphics commands in PostScript into color specifications for each dot of toner deposited on a page by the copier.

How the Fiery XJ works

The Fiery XJ receives files from computers on the network, processes (RIPs) those files, and then sends them to the copier’s print engine for printing. Even with the Fiery XJ installed, you can still use the copier to make copies.

When printing from an application, your Windows or Mac OS computer communicates with the Fiery XJ by means of a PostScript printer driver and a PostScript printer description file (PPD).

About PostScript printer drivers and PPDs

A PostScript printer driver is an application that manages printing communication between your application software and the printer. It interprets the instructions generated by the application software, merges those instructions with printer-specific PPD options you specify (see below), and translates all that information into PostScript, a language the printer understands. In other words, the printer driver writes a PostScript file based on your original file and the options you set from the Print dialog box.

A PPD file contains information about a particular device's features and capabilities (for example, what paper sizes and media types are supported). The PostScript printer driver reads the information in the PPD file and presents that information to you in the form of options you can choose from the Print dialog box. The PPD for the Fiery XJ includes information about the features of both the copier and the Fiery XJ.

For information on the PPD options for your Fiery XJ, see Appendix A, "Print Options."

Supported paper sizes

The Fiery XJ supports printing at 400 dpi (dots per inch) on the following paper sizes:

- 8" x 10"-R
- Letter, Letter-R (8.5" x 11")
- Legal 13 (8.5" x 13")
- Legal (8.5" x 14")
- Tabloid (11" x 17")
- A6-R (105 mm x 148 mm)
- A5, A5-R (148 mm x 210 mm)
- A4, A4-R (210 mm x 297 mm)
- A3 (297 mm x 420 mm)

Fiery XJ job environments

The Fiery XJ supports several levels of control of printing, job management, and setup, and offers you the flexibility to choose the configuration that corresponds to the requirements of your site. If desired, the administrator can implement controls that limit user access to certain Fiery XJ functions, including Fiery XJ configuration (Setup), calibration, job overrides, and font management.

The spectrum of control that an administrator can implement is described fully in the *Administrator Guide*.

Permissions

Support for various types of job environments is achieved by a combination of Fiery XJ Setup options. By default, anyone can access Setup, but the administrator can limit access to Setup by specifying an Administrator password for the Fiery XJ (see the *Administrator Guide*).

The two security levels are:

- **Administrator**—confers control of Setup and is the highest level of control. The person who has access to Setup can control the printing and job management environment by choosing which print connections are enabled, and by electing to set passwords.
- **Guest**—allows users to view the status of active jobs and the list of stored jobs. They cannot make changes to jobs. A password is not needed to log in as Guest and view jobs from the Fiery WebSpooler or Fiery Spooler windows.

This manual describes the features of the Fiery WebTools and Fiery client utilities, as well as all privileges, whether those privileges are available to everyone or are exclusive to only certain people. It also includes descriptions of administrator functions, sometimes referring you to other manuals for more information.

Before you begin

Before using the Fiery XJ, follow these steps:

1. Confirm that the system administrator has completed Setup as described in the *Administrator Guide*.
2. Determine which printer defaults the administrator has specified in Setup.
These default settings can affect the results of your print jobs. Check with your administrator or operator for information on these default settings.
3. Confirm that the user software is installed correctly on your workstation, as described in *Getting Started*.
4. Find out how your workstation is configured for printing on the network.
If you send a job to the Print queue, the job spools to the Fiery XJ and proceeds to RIP and print according to your job settings—unless someone intervenes with Fiery WebSpooler or Fiery Spooler.
You may also have access to the Direct connection, which sends jobs straight to the server without spooling and is used to download printer fonts to the Fiery XJ disk.
5. Determine whether the Fiery XJ is set up to use Fiery WebTools and what your access privileges are.
The administrator may or may not have enabled access to the server via the Internet (or an intranet). If access is enabled, a password may be required to perform job management with Fiery WebSpooler or Fiery Spooler.

Chapter 1: Using the Control Panel

You can use the Fiery XJ Control Panel to view status information, print special pages, and set up printing.

Introduction to the Fiery XJ Control Panel

The Control Panel, shown below on the front of the Fiery XJ, comprises the following parts:

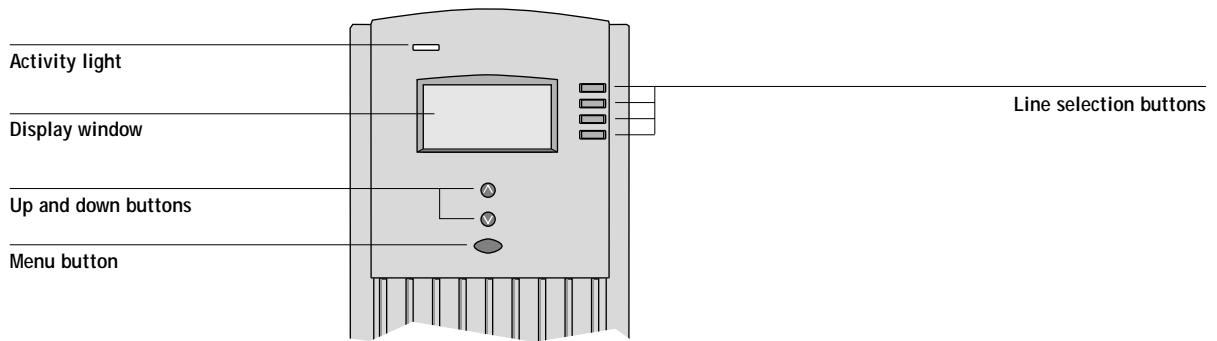

Activity light

The activity light indicates the current Fiery XJ activity. If the light is:

Solid red	An error has occurred causing the Fiery XJ to be disabled.
Flashing red	There is an error causing printing to be disabled, but the Fiery XJ is capable of processing.
Solid green	The Fiery XJ is idle.
Flashing green	The Fiery XJ is processing or printing a job, or communicating with a remote computer.
No light	The Fiery XJ is off or starting up.

Buttons

Line selection buttons	There are four line selection buttons on the right side of the Control Panel. Use these buttons to select the command displayed on the corresponding line of the display window. When a button is active, a special character (>) appears in the display window next to the button.
Up and down buttons	Use these buttons to scroll to different screens in multi-screen lists, to select Setup options from a list of available options, and to scroll alphanumeric characters.
Menu button	Press this button to view other screens. Under normal operation, the Control Panel displays the Info, RIP, or Print Status screen with information about the status of the Fiery XJ. If you press the Menu button, the Functions menu is displayed and you can perform additional operations (see page 1-4). If a job is processing or printing, press the Menu button to cycle among the active screens.

Display window

The display window provides information about the status of the Fiery XJ, displays menu information, and enables you to view and edit information in the Setup menus.

The last line of the display window displays text that tells you what screen you are looking at and highlights one of the icons to indicate what the Fiery XJ is doing. Only the icons for the screens that are currently available appear. The menu button cycles among the active screens.

The screens are:



Alert Status

If there is a problem with processing a job or printing functions, an error message appears on the Control Panel. For information on error messages, see Appendix C, “Troubleshooting.”

**Print Status**

When the Fiery XJ is printing a job, the Print Status screen appears. This screen displays the following:

Cancel Job—Press the top line selection button to cancel the job currently printing.

User name—The name of the user who sent the job currently processing.

Pages/Total—The number of copies of the current job printed and the total number of copies of the job requested.

**RIP Status**

When the Fiery XJ is processing a job, the RIP Status screen appears. This screen displays the following:

Cancel Job—Press the top line selection button to cancel the job currently processing. The Fiery XJ cancels the job before printing begins.

Document name—The name of the document currently processing.

User name—The name of the user who sent the job currently processing.

Kilobytes—The size (in kilobytes) of the job processed so far. **NOTE:** This number is always displayed in kilobytes, even if the amount goes over 1000KB; for example, 10MB is displayed as 10000KB.

**Info Status**

When the Fiery XJ is not processing or printing a job, it displays information about the current server and software. It displays the following information:

Server Name—The Fiery XJ name.

Status—The current status of the Fiery XJ. The Fiery XJ status can be: Idle, Initializing, Busy, Processing, or Printing.

Megabytes—The space (in megabytes) available on the Fiery XJ hard disk, for example, 756MB.

Version—The system software version running on the Fiery XJ.

**Functions**

You can press the Menu button to display the Functions menu. Use the up and down buttons to scroll through the list. Press the line selection button to the right of a command to select that command. See page 1-4 for more information.

**Network**

The network icon appears at the bottom left of any of the other screens when a job is being sent to the Fiery XJ, either over the network or through the parallel port. The network icon also appears, together with a flashing green activity light, when a remote utility is running.

Functions menu

The Functions menu provides the following commands:

Print Pages

Print special pages from the Fiery XJ. You can print the following pages from the submenu that appears:

Test Page—A Test Page enables you to confirm that the Fiery XJ is properly connected to the copier, and provides color and grayscale samples to troubleshoot problems with the copier or the Fiery XJ. The following settings are among those listed on the Test Page: Server Name, Printer Model, color settings, calibration information, date and time the Test Page was printed.

Configuration—Prints the Configuration page, which gives the current server and device configuration. This page lists general information about the hardware and software configuration of the Fiery XJ, the current options for all Setup settings, information about the current calibration, and the Ethernet and Token Ring addresses of the Fiery XJ.

Job Log—Prints a log of the last 55 jobs. For information on the fields in the Job Log and on printing it in other forms, see Chapter 6, "Tracking and Managing Print Jobs."

Control Panel Map—Prints the Control Panel Map, which is an overview of the screens you can access from the Control Panel. For information about using these screens to set up the Fiery XJ, see the *Administrator Guide*.

Font List—Prints a list of all fonts currently on the Fiery XJ hard disk.

Suspend Printing

Suspend communication between the Fiery XJ and the copier. You *must* suspend printing if you want to interrupt the current Fiery XJ job so that you can use the copier to make copies. Jobs continue to process on the Fiery XJ. After you make the copies, select Resume Printing to continue printing jobs from the Fiery XJ and networked users.

NOTE: Do not select Suspend Printing while printing sort jobs.

Resume Printing

Resume communication between the copier and the Fiery XJ after you have finished making copies.

Run Diagnostics

This function is provided for service representatives only. Contact your authorized service/support technician for information about running diagnostics.

Reboot Server

Shut down all Fiery XJ activity in the correct manner and then restart. You should use this option instead of the power switch on the back of the Fiery XJ.

Starting and shutting down the Fiery XJ

Generally, you can leave the Fiery XJ running all the time. This section describes how to shut down and restart the Fiery XJ when necessary.

Starting the Fiery XJ

To start the Fiery XJ, move the power switch on the back of the Fiery XJ to the On position. If the copier is also powered off, power it on before powering on the Fiery XJ.

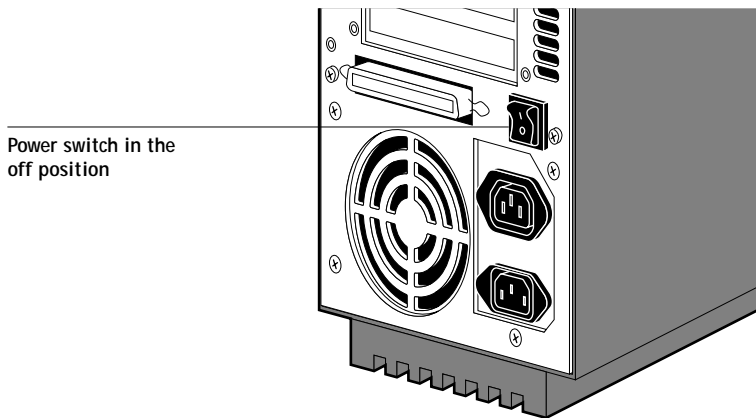

Diagnostic messages appear on the Fiery XJ Control Panel. If any diagnostics fail, more information and instructions appear. Contact your service representative if the Fiery XJ encounters problems while running the diagnostics.

When the diagnostics are finished, the following message is displayed:

For software update or setup, press any key.

If you want to change Setup option settings, press any button; if you do not press a button, the Fiery XJ continues starting up and displays the message *Idle* when it is ready to receive data.

NOTE: If an Administrator password has been set, you are required to enter it to access Setup.

If you press a button, the following options appear. For information about the Setup menus and options, see the *Administrator Guide*.

Choose:	To do this:
Exit Setup	Exit the Setup menus; the Fiery XJ reboots.
Server Setup	Enter the Server Setup menus.
Network Setup	Enter the Network Setup menus.
Printer Setup	Enter the Printer Setup menus.
PS Setup	Enter the PostScript Setup menu.
Color Setup	Enter the Color Setup menu.
Job Log Setup	Enter the Job Log Setup menu.
Calibration	Calibrate the Fiery XJ using AutoCal. For more information, see “Calibrating with AutoCal from the Control Panel” on page 7-5 and the <i>Administrator Guide</i> .
Change Password	Change the Administrator password.
Clear Server	Clear all jobs in all server queues as well as the Job Log. Check with your administrator or operator before choosing Clear Server.

Restarting the Fiery XJ

You should use the procedure described below to restart the Fiery XJ rather than using the power switch on the back of the Fiery XJ.

TO RESTART THE FIERY XJ:

1. Make sure that the Fiery XJ is not receiving, processing, or printing a job.

Make sure that the status message on the Control Panel is Idle.

NOTE: If a job from the Print queue is processing, it will continue processing and print after the Fiery XJ is restarted; if a job sent to the Direct connection is processing, it will not finish processing or printing.

2. Press the Menu button to display the Functions menu.
3. Use the up and down buttons to scroll to the last screen and choose Reboot Server.

Shutting down the Fiery XJ

You may need to shut down the Fiery XJ for service. When you do so, fonts that have been downloaded to the hard disk drive are not deleted. Print jobs in the Printed queue and jobs that have been processed but not printed are not deleted and are available for printing when you restart the Fiery XJ.

TO SHUT DOWN THE FIERY XJ:

1. Make sure that the Fiery XJ is not receiving, processing, or printing a job.

Make sure that the status message on the Control Panel is Idle. If a job has just finished processing or printing, wait at least five seconds after the Control Panel status message switches to Idle before proceeding to step 2.

NOTE: If a job from the Print queue is processing, it will continue processing and print after the Fiery XJ is restarted; if a job to the Direct connection is processing, it will not finish processing or printing.

2. Power off the Fiery XJ by moving the power switch on the back to the Off position.

NOTE: After powering off the Fiery XJ, make sure to also power off the copier. Leaving the copier powered on while the Fiery XJ is powered off can lead to excessive drain on the Fiery XJ motherboard battery.

Safety warnings

The Fiery XJ display window is a liquid crystal display (LCD) that is made of glass and can break. Do not subject it to strong shocks.

If the display window breaks and the liquid crystal material leaks out, do not inhale, ingest, or touch it. If the material gets on your skin or clothing, wash it off with soap and water immediately.

Cleaning the Fiery XJ

Clean the Fiery XJ with a soft cloth moistened with isopropyl alcohol or ethyl alcohol. *Never* use water or ketone as these may permanently alter the display.

Chapter 2: Printing from Windows Computers

This chapter describes how to print to the Fiery XJ from Windows 95 and Windows NT 4.0.

You can print from a networked Windows computer, or from a Windows computer connected to the parallel port on the Fiery XJ. If you plan to print files at another location, you should follow the procedures described in “Saving files to print at a remote location” on page 2-8.

Another way to print from a Windows computer is to download PostScript or Encapsulated PostScript (EPS) files using Fiery Downloader.

NOTE: For information on setting up the Windows environment for printing with Windows servers connected to the Fiery XJ, see the *Administrator Guide*. For information on how to connect to the Fiery XJ over the network, install printer drivers, and install the Fiery utilities, see *Getting Started*.

Printing from applications

Once you have installed the Fiery XJ printer driver and set it to the proper port as described in *Getting Started*, you can print directly from most Windows applications. Simply choose the Print command from within your application.

Setting options and printing from Windows 95

To print from Windows 95, use the Adobe PostScript printer driver for Windows 95. The driver is included with the Fiery XJ user software, and uses all features of the Fiery XJ.

Once you have installed the Adobe PostScript printer driver and Fiery XJ PostScript Printer Description file (PPD), you can specify print settings. You can also change settings for a particular job when you print it to the Fiery XJ. Before printing, make sure that the correct print options are set.

To print from Windows 95 applications over a network, you must be connected to a print server. This can be a Novell NetWare server, an NT server, or a UNIX server. For information about connecting a server to the Fiery XJ, see the *Administrator Guide*. Alternatively, you can print from Windows 95 without connecting to a print server via SMB printing. For information about setting up SMB printing, see *Getting Started*.

TO SET PRINT OPTIONS AND PRINT WITH THE ADOBEPS PRINTER DRIVER FROM WINDOWS 95:

1. Double-click the My Computer icon.
2. Double-click the Printers icon.
3. Select the icon for the Fiery XJ and choose Properties from the File menu.
4. Click the Paper tab.
5. Specify the appropriate settings for the print job.

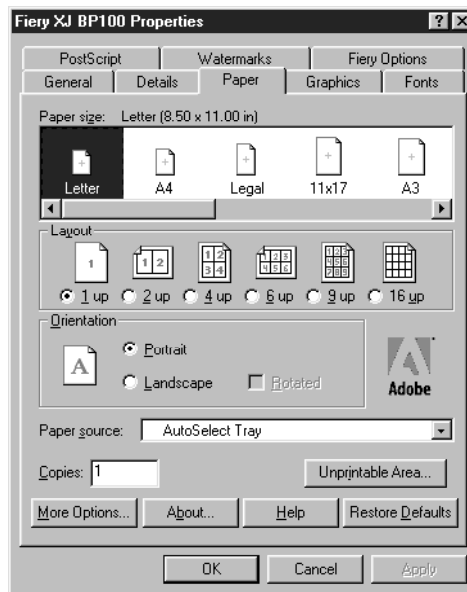

In the Paper size area, specify the page size for the job.

From the Paper source pop-up menu, choose the paper tray for the job. For example, you can specify that the job should be printed on pages in the Bypass tray. The Paper source selection is valid for the current job only.

NOTE: If paper loaded in the selected tray is a different size, orientation, and/or media type than that of the job you are sending, the Fiery XJ displays an error message and the job will not print. You should then load the correct paper in the selected tray or cancel the job.

6. To select a specific media type, click More Options.
7. From the Paper type pop-up menu, choose the type of media to use for the job and click OK.

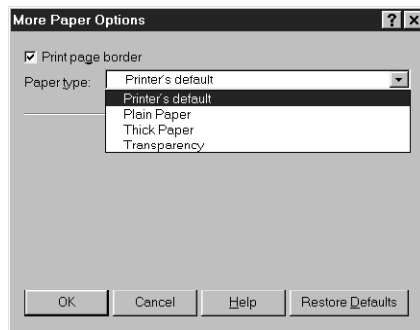

8. Click the Fiery Options tab.

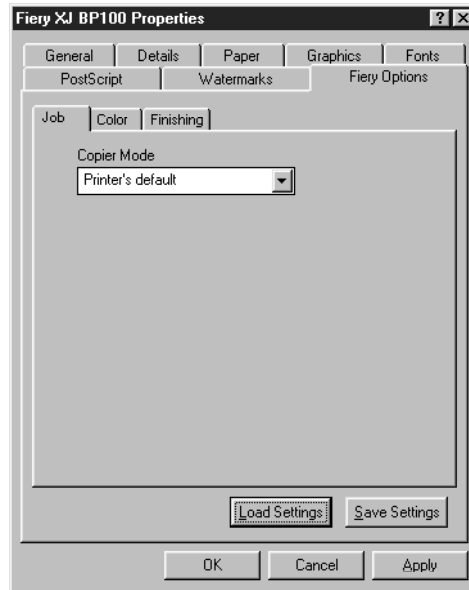

9. Go to the Job, Color, and Finishing tabs, and specify the appropriate settings for the print job.

These print options are specific to the Fiery XJ. They override settings in Fiery XJ Printer Setup; the settings can also be changed in the Override Print Settings dialog box with the Fiery WebSpooler or Fiery Spooler. For information about these options and overrides, see Appendix A, “Print Options.”

If you choose Printer’s default, the Fiery XJ prints with the default setting specified during Setup.

10. If you want to make the new settings the default settings, click Apply.
11. Click OK.

12. From your application, choose Print.

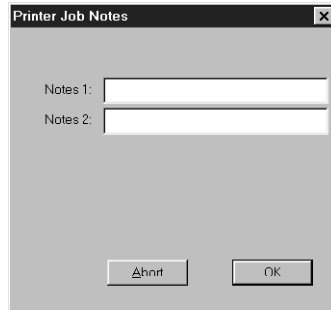

13. Enter text messages in the Notes 1 and Notes 2 areas.

Enter user and job identification information for accounting purposes, or whatever information is required at your site. These notes will appear in the Job Log.

14. Click OK.

NOTE: The Fiery XJ does not support printing the Cover Page from the AdobePS printer driver.

Saving and loading print option settings

Print option settings can be saved to a settings file on your hard disk. Saving a settings file enables you to easily load specifically configured settings for a particular job.

TO SAVE PRINT OPTION SETTINGS:

1. After configuring the options from the Job, Color, and Finishing tabs, click Save Settings.
2. Name the settings file and browse to a location on your hard disk where you want to save the file.
3. Click OK.

The settings file is saved to the location you specified.

TO LOAD PRINT OPTION SETTINGS:

1. From the Fieri Options tab, click Load Settings.
2. Browse to the settings file.
3. Select the settings file from the list and click OK.

The options from the Job, Color, and Finishing tabs are automatically configured with the saved settings.

Setting options and printing from Windows NT 4.0

You can print from Windows NT 4.0 using the printer driver included with Windows NT.

TO SET PRINT OPTIONS AND PRINT WITH THE MICROSOFT POSTSCRIPT PRINTER DRIVER FROM WINDOWS NT 4.0:

1. Choose Print in your application and click Properties.
2. Click the Advanced tab.
3. Specify the appropriate settings for the print job.

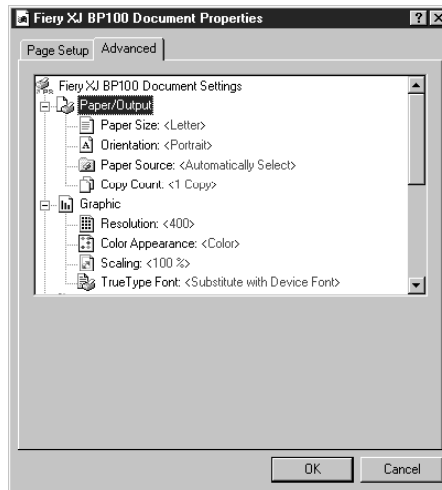

In the Paper Size menu, specify the page size for the job.

From the Paper Source menu, choose the paper tray for the job. For example, you can specify that the job should be printed on pages in the Bypass tray. The Paper Source selection is valid for the current job only.

NOTE: If paper loaded in the selected tray is a different size, orientation, and/or media type than that of the job you are sending, the Fiery XJ displays an error message and the job will not print. You should then load the correct paper in the selected tray or cancel the job.

4. Scroll down to Printer Features, and select the appropriate settings for the print job.

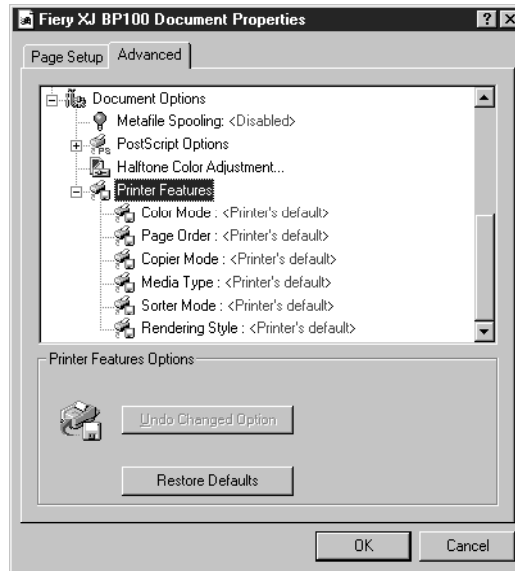

These print options are specific to the Fiery XJ. They override settings in Fiery XJ Printer Setup; the settings can also be changed in the Override Print Settings dialog box with the Fiery WebSpooler or Fiery Spooler. For information about these options and overrides, see Appendix A, “Print Options.”

If you choose Printer's default, the Fiery XJ prints with the default setting specified during Setup.

5. Click OK, then click OK in the Print dialog box.

NOTE: The Fiery XJ does not support printing the Cover Page from the Microsoft PostScript printer driver for Windows NT 4.0.

Printing to the parallel port

The Fiery XJ has a parallel port that enables you to print most files directly from a Windows computer if your network administrator has connected the Windows computer's parallel port to the Fiery XJ parallel port.

NOTE: You cannot use Fiery Downloader through the parallel port.

TO PRINT FILES TO THE PARALLEL PORT:

1. Make sure the parallel port is enabled on the Fiery XJ.
Check with your site administrator to see whether printing to the parallel port is enabled. See *Getting Started* for information on setting up parallel port printing on your Windows computer.
2. Select the printer port that is connected to the Fiery XJ parallel port.
Select one of the local ports: LPT1, LPT2, or LPT3. For instructions, see your Windows documentation.
3. Print from within your application.

Saving files to print at a remote location

If you do not have a Fiery XJ and are preparing files to take to a service bureau or other location, print the final files to the File port (as opposed to one of the local ports). You can also print to the File port to create a file to be downloaded using Fiery Downloader. For instructions, see your Windows documentation.

Using Fiery Downloader to print

Downloading files with Fiery Downloader is generally faster than printing from application software. You can use Fiery Downloader to print PostScript or EPS files.

TO PRINT USING FIERY DOWNLOADER:

1. Create a PostScript or EPS file. Specify the appropriate print options and include (embed) any necessary fonts that are not resident on the Fiery XJ.

For a list of fonts resident on the Fiery XJ, see Appendix B, “Font List.”

2. Launch Fiery Downloader and connect to the Fiery XJ.

For instructions on setting up Fiery Downloader, see *Getting Started*.

3. Select the file(s) you want to download, and specify any necessary options.

4. Click Download.

For details, see Chapter 5, “Downloading Files and Fonts.”

Chapter 3: Printing from Mac OS Computers

You can print to the Fiery XJ just as you would print to any other printer from any application software. First, select the Fiery XJ as the current printer in the Chooser, and then print the file from within your application.

Another way to print from a Mac OS computer is to download PostScript or Encapsulated PostScript (EPS) files using Fiery Downloader.

Printing from applications

Before you can print to the Fiery XJ from applications, you must select the Fiery XJ in the Chooser. Then, using the Adobe PostScript printer driver and the correct PostScript Printer Description file (PPD), you can control many Fiery XJ printing features by specifying job settings from print dialog boxes.

Selecting the Fiery XJ in the Chooser

Before you print a job, make sure the Fiery XJ is the currently selected printer.

TO SELECT THE FIERY XJ AS THE CURRENT PRINTER:

1. Make sure the Fiery XJ is connected to the network and turned on.
2. Choose Chooser from the Apple menu.
3. Click the AdobePS icon to select it.
4. If the network is divided into zones, select the zone in which the Fiery XJ is located.
5. Select the Fiery XJ by <Server Name>_<Device Name>_<Queue Name> from the "Select a PostScript Printer" list.

The names of all supported printers in the zone appear in the scroll list on the right. For information about setting up the Fiery XJ in the Chooser, see *Getting Started*.

NOTE: If your system administrator has not enabled the connection to the Print queue or the Direct connection, the corresponding name will *not* appear in this list.

6. Make sure that AppleTalk is set to Active, and then close the Chooser window.

The Fiery XJ remains selected as the current printer until you choose a new printer in the Chooser.

Setting print options and printing from Mac OS computers

In Mac OS applications, print options are set from both the Page Setup dialog box and the Print dialog box. For details, see Appendix A, “Print Options.”

NOTE: Some default print options are set by the administrator during Setup. Check with the administrator for information on the current server default settings.

TO SET PRINT OPTIONS AND PRINT WITH THE ADOBEPS PRINTER DRIVER:

1. Open the file you want to print, and choose Page Setup from the application's File menu.

The AdobePS Page Setup dialog box appears.

2. In the Paper pop-up menu, specify the page size for the job and click OK.
3. Choose Print from the application's File menu.

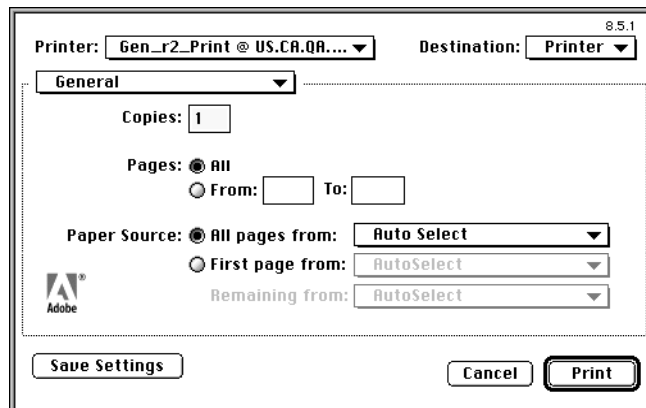

NOTE: Print dialog boxes vary across applications.

If the Print dialog box lets you select from a pop-up menu of available printers, choose the Fiery XJ.

From the Paper Source pop-up menu, choose the paper tray for the job. For example, you can specify that the job should be printed on pages in the Bypass tray. The Paper Source selection is valid for the current job only.

NOTE: If paper loaded in the selected tray is a different size, orientation, and/or media type than that of the job you are sending, the Fiery XJ displays an error message and the job will not print. You should then load the correct paper in the selected tray or cancel the job.

4. From the General pane, choose Job Notes.

In the Notes 1 and Notes 2 areas, enter user and job identification information for accounting purposes, or whatever information is required at your site. These notes will appear in the Job Log.

5. From the Job Notes pane, choose Printer Specific Options.

6. Specify the appropriate settings for the print job.

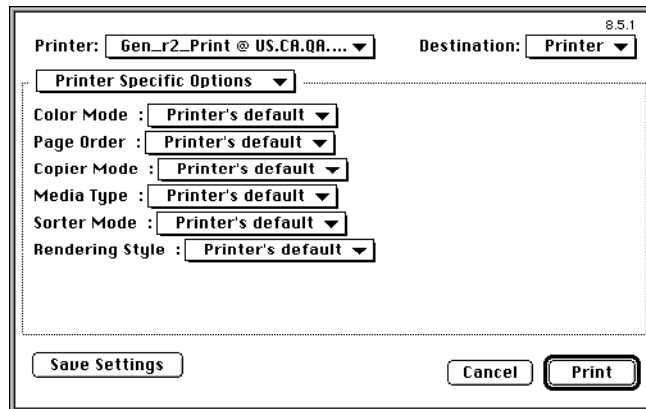

These print options are specific to the Fiery XJ (you may need to scroll to see all the options). They override settings in Fiery XJ Printer Setup; the settings can also be changed in the Override Print Settings dialog box with the Fiery WebSpooler or Fiery Spooler. For information about these options and overrides, see Appendix A, “Print Options.”

If you choose Printer's default, the Fiery XJ prints with the default setting specified during Setup.

Some PPD options are ones that could also be set from an application (for example, Reverse Order printing or Collation). In these cases, use the PPD option to perform the function, rather than setting it from the application. The application may not set up the file properly for printing on the Fiery XJ and may also take longer to process.

7. If you want to make the new settings the default settings, click Save Settings.
8. Click Print.

NOTE: The Fiery XJ does not support printing the Cover Page from the AdobePS printer driver.

Using Fiery Downloader to print

Downloading files with Fiery Downloader is generally faster than printing from application software. You can use Fiery Downloader to print PostScript or EPS files.

TO PRINT USING FIERY DOWNLOADER:

1. Create a PostScript or EPS file. Specify the appropriate print options and include (embed) any necessary fonts that are not resident on the Fiery XJ.
For a list of fonts resident on the Fiery XJ, see Appendix B, “Font List.”
2. Launch Fiery Downloader and connect to the Fiery XJ.
For instructions on setting up Fiery Downloader, see *Getting Started*.
3. Select the file(s) you want to download, and specify any necessary options.
4. Click Download.

For details, see Chapter 5, “Downloading Files and Fonts.”

Chapter 4: Printing from UNIX Workstations

You can print to the Fiery XJ directly from UNIX. Jobs printed to the Fiery XJ are sent to the Print queue and can be manipulated from Windows and Mac OS computers on the network using Fiery WebSpooler or Fiery Spooler.

The queue name and Fiery XJ printer name are established by your system administrator. Contact your system administrator for the names of your queues.

For information about setting up printing from TCP/IP, see your UNIX system documentation.

Printing to the Fiery XJ

You can use UNIX commands to print PostScript files and text files to the Fiery XJ. In general, the basic print commands (`lpr`, `lpq`, `lprm`) can be used to send print jobs to a Fiery XJ. See your UNIX manual pages or other documentation for information about UNIX commands.

NOTE: Only PostScript or text file formats can be printed from UNIX.

TO PRINT FROM UNIX:

- On a system running SunOS 4.1.x or another BSD-based variant, use the `lpr` command to send a job to the Fiery XJ as follows:

```
lpr <-Pprinter> <-#copies> <filename>
```

For example, if the Print queue of your Fiery XJ is named `print_Server`, your file is named `Sample`, and you want to print two copies, type:

```
lpr -Pprint_Server -#2 Sample
```

- On a system running Solaris® 2.x or any System V implementation of UNIX, use the `lp` command to send a job to the Fiery XJ as follows:

```
lp -d <printrname> {-n <#copies>} <filename>
```

For example, if the Print queue of your Fiery XJ is named `print_Server`, your file is named `Sample`, and you want to print two copies, type:

```
lp -d print_Server -n 2 Sample
```

TO DISPLAY A LIST OF JOBS IN THE QUEUE:

- On a system running SunOS 4.1.x or another BSD-based variant, use the `lpq` command to see printer jobs in the queue as follows:

```
lpq <-Pprinter>
```

For example, if the Print queue of your Fiery XJ is named `print_Server`, type:

```
lpq -Pprint_Server
```

Your workstation displays the contents of the queue.

- On a system running Solaris 2 or any System V implementation of UNIX, use the `lpstat` command to see printer jobs in the queue as follows:

```
lpstat -o <printrname>
```

For example, if the Print queue of your Fiery XJ is named `print_Server`, type:

```
lpstat -o print_Server
```

Your workstation displays the contents of the queue.

TO REMOVE JOBS FROM THE QUEUE:

NOTE: Unless you log in as the root user, you can remove only your own jobs.

- On a system running SunOS 4.1.x or another BSD-based variant, use the `lprm` command to remove jobs from the queue as follows.

```
lprm <-Pprinter> <job #...>
```

You can use the `lpq` command to check the job number.

For example, to remove job number 123 from the Print queue of your Fiery XJ named `print_Server`, type:

```
lprm -Pprint_Server 123
```

The `lprm` command reports the names of any files it removes.

- On a system running Solaris 2.x or any System V implementation of UNIX, use the `cancel` command to remove jobs from the queue.

```
cancel <printername> <job ID>
```

For example, to remove job number 123 from the Print queue of your Fiery XJ named `print_Server`, type:

```
cancel print_Server 123
```

Chapter 5: Downloading Files and Fonts

Fiery Downloader allows you to send PostScript and EPS files directly to the Fiery XJ without using the application in which they were created. It also enables you to manage printer fonts on the Fiery XJ.

You can use Fiery Downloader from a remote Windows 95, Windows NT 4.0, or Mac OS workstation. Fiery Downloader requires a network connection—you *cannot* use Fiery Downloader with the parallel port. For information on supported networking protocols, see *Getting Started*.

NOTE: The Windows and Mac OS versions of Fiery Downloader are fundamentally the same; differences are noted in this chapter. Where a window or dialog box is illustrated, the Windows version comes first, followed by the Mac OS version.

Using Fiery Downloader

You can use Fiery Downloader to:

- Send PostScript and EPS files to the Fiery XJ
- Check the status of the Fiery XJ
- Manage the PostScript printer fonts stored on the Fiery XJ hard disk (this feature requires that Publish Direct Connection is set to Yes in Fiery XJ Printer Setup)

NOTE: Fiery Downloader was designed specifically for the Fiery XJ; you cannot use it with any other printer.

TO VIEW INFORMATION WITH FIERY DOWNLOADER:

1. Launch Fiery Downloader.
2. Select the Fiery XJ in the Chooser window and click OK (Windows) or Connect (Mac OS).

The Fiery Downloader Status window appears and you see the Fiery Downloader Toolbar, menus, and the status bar at the bottom of the screen.

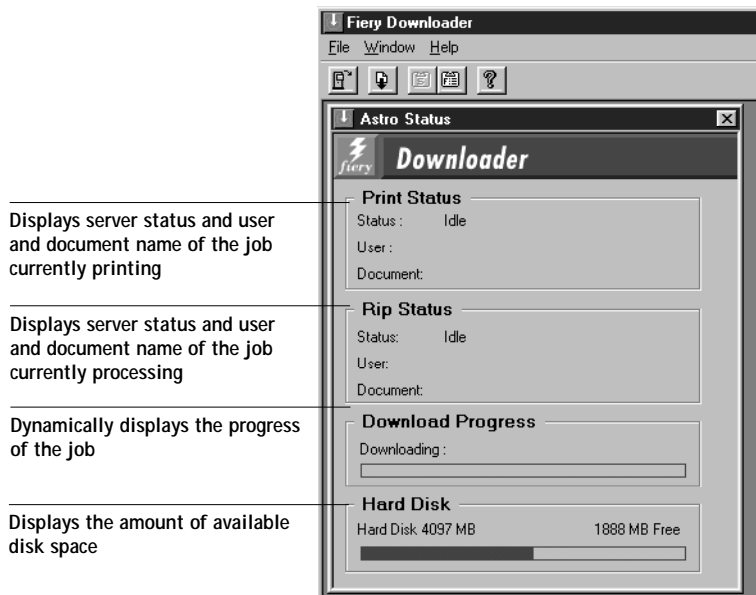

Buttons for some menu functions appear in the Toolbar at the top of the window:



Open

Click to connect to a different Fiery XJ.



Download

Click to download a file or font to the Fiery XJ.



Status

If you are viewing the font list, click to display the status window for the current Fiery XJ.



Font list

If you are viewing the status window, click to display a list of printer fonts on the Fiery XJ hard disk.



About Fiery
Downloader
(Windows only)

Click to view version information about Fiery Downloader.

You can click the Font list button or choose Font List from the File menu to view font information in the window.

3. To select a different Fiery XJ, choose Open from the File menu or click the Open button.
4. Select the Fiery XJ in the dialog box that appears, and click OK (Windows) or Connect (Mac OS).
5. To close the connection to the Fiery XJ, make sure the Status window is active and choose Close from the File menu or click the close box in the Status window.
6. To quit Fiery Downloader, choose Exit (Windows) or Quit (Mac OS) from the File menu.

Printing with Fiery Downloader

Printing files with Fiery Downloader is fast—generally faster than printing from within applications. If you regularly print large files, try printing with Fiery Downloader.

TO DOWNLOAD A FILE OR FONT WITH FIERY DOWNLOADER:

1. Use your application to generate a file.

You can save a PostScript file by selecting the appropriate option in the application's Print dialog box. With some applications, you can save EPS files.

If you experience problems printing EPS files with Fiery Downloader, you can print the file directly from the application in which it was created.

2. Launch Fiery Downloader.

5

5-4 Downloading Files and Fonts

3. Choose Download from the File menu or click the Download button.

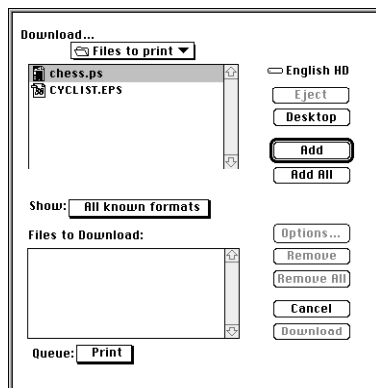
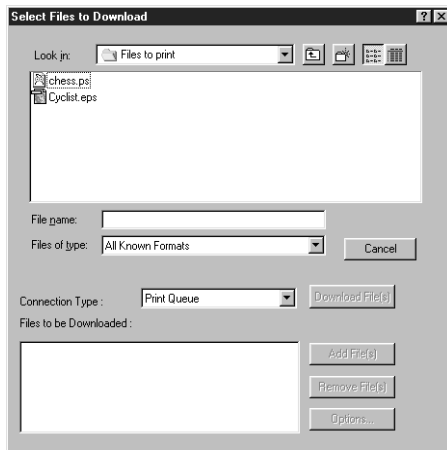

4. Choose the file type to display from the Files of type (Windows) or Show (Mac OS) menu.

You can leave this at the default **All Known Formats** or choose **All Files**. All Known Formats lists all files in formats supported by Fiery Downloader.

You can download files and fonts in the same batch. If the fonts are used by files in the same batch, the fonts should be downloaded first.

To download fonts, you must use the Direct connection (make sure that Publish Direct Connection is set to Yes in Printer Setup on the Fiery XJ). If you do not have access to the Direct connection, you must embed any special fonts used by the file in the file when you generate it.

5. Choose the Connection Type (Windows) or Queue (Mac OS) to which you will download the files.

The options available to you in this menu depend on the Setup at your site. The potential selections are the Print Queue (Windows) or Print (Mac OS), or Direct Connection (Windows) or Direct (Mac OS). If your administrator has not enabled one or more of these connections, you cannot select it.

6. Select the filename and click Add File(s) (Windows) or Add (Mac OS).

The File name field (Windows) displays the name of the selected file before you click Add.

You can navigate to different drives and directories to select files to download. Click Add All (Mac OS) to add all files in a folder.

To select multiple sequential files, select the first file and then shift-click the last file. Control-click to select multiple non-sequential files.

If you change your mind about a file, select the filename in the Files to (be) Download(ed) list and click Remove File(s) (Windows) or Remove (Mac OS).

Click Remove All (Mac OS) to remove all files from the Files to Download list.

7. To change the attributes of a file to be downloaded, select it and click Options.
8. Specify the following information in the dialog box and click OK:

The options you set apply only to the selected file. You can set different options, or leave the default settings, for each file.

Copies—Specify the number of copies to print.

Brightness—This option is not supported on the Fiery XJ.

'showpage' after EPS files (Windows) or 'showpage' (Mac OS) (EPS files only)—In most cases, you do not need to use this option. Select the 'showpage' option only if an EPS file fails to print without it. This option adds a showpage PostScript language command at the end of the print job. Some applications omit this necessary PostScript

language command when they generate EPS files. Select this option when printing EPS files generated by these applications. If you select this option unnecessarily, extra blank pages may print.

If you experience problems printing EPS files with Fiery Downloader, you can print the file directly from the application in which you created it.

9. Click **Download File(s) (Windows)** or **Download (Mac OS)**.
10. To cancel downloading, press **Esc (Windows)** or **Command-.** (Mac OS).

Downloading and managing printer fonts

The Fiery XJ includes 136 built-in PostScript fonts; for a complete list, see Appendix B, “Font List.” In addition, two Adobe Multiple Master fonts are included and are used for font substitution in PDF files.

NOTE: Publish Direct Connection must be set to Yes in Fiery XJ Printer Setup in order to download and manage fonts, and to view the font list.

Before downloading a file that uses fonts not resident on the Fiery XJ, you must download the fonts (unless the fonts are embedded in the file). To see what fonts are resident on the Fiery XJ, choose Font List from the File menu or click the font list button (see page 5-2).

You can download fonts only via the Direct connection. If you do not have access to the Direct connection, you must embed any special fonts used by the file in the file when you generate it.

The screen fonts that correspond to the printer fonts installed on the Fiery XJ are not automatically installed on your Windows system.

NOTE: You cannot use Fiery Downloader to download TrueType fonts. If you use TrueType fonts in Windows, you can print them by converting them to Adobe Type 1 fonts. To do this with the AdobePS driver, click the Fonts tab and set up the Font Substitution Table as necessary.

Printer fonts and Mac OS screen fonts

Like all PostScript fonts, the fonts included with the Fiery XJ come in two forms: printer fonts and screen fonts. The printer fonts are installed permanently on the Fiery XJ hard disk. The screen fonts should be installed on your Mac OS computer. If you are using these fonts in documents you print on another printer, they are probably already installed. If not, you will need to install them yourself.

Occasionally, you may want to use Adobe Type 1 (Windows) or PostScript (Mac OS) fonts that are not included with the Fiery XJ. If so, you will need to install the screen fonts on your computer and the printer fonts on the Fiery XJ. To do this, follow the instructions from the font manufacturer.

Downloading printer fonts to the Fiery XJ

In general, each time you print from within a Mac OS application, the application automatically downloads any fonts used in your document that are not already installed on the Fiery XJ, as long as the printer fonts are installed in your System Folder. These fonts remain in the Fiery XJ only until your document has printed. If you print the same document again, your application must download the fonts again.

If you regularly use one or more fonts from Windows or Mac OS applications that are not already installed in the Fiery XJ, you can save time by downloading them to the Fiery XJ hard disk with Fiery Downloader. Fonts you download to the Fiery XJ hard disk remain installed until you remove them using Fiery Downloader, no matter how many times the Fiery XJ is turned off and on. You'll probably want to download fonts you use on a regular basis to the Fiery XJ hard disk.

Before you download files with Fiery Downloader, make sure that all fonts included in your file are installed in the Fiery XJ or embedded in your file; otherwise the text in these fonts will not print correctly and may not print at all.

TO VIEW FONT INFORMATION, UPDATE, PRINT, AND DELETE FONTS:

- Choose Font List from the File menu or click the Font List button.

The Font List window appears with Update, Print, and Delete buttons in the title bar. The printer fonts included with the Fiery XJ (resident fonts) are locked. Locked fonts appear with a lock icon next to the name and cannot be deleted.

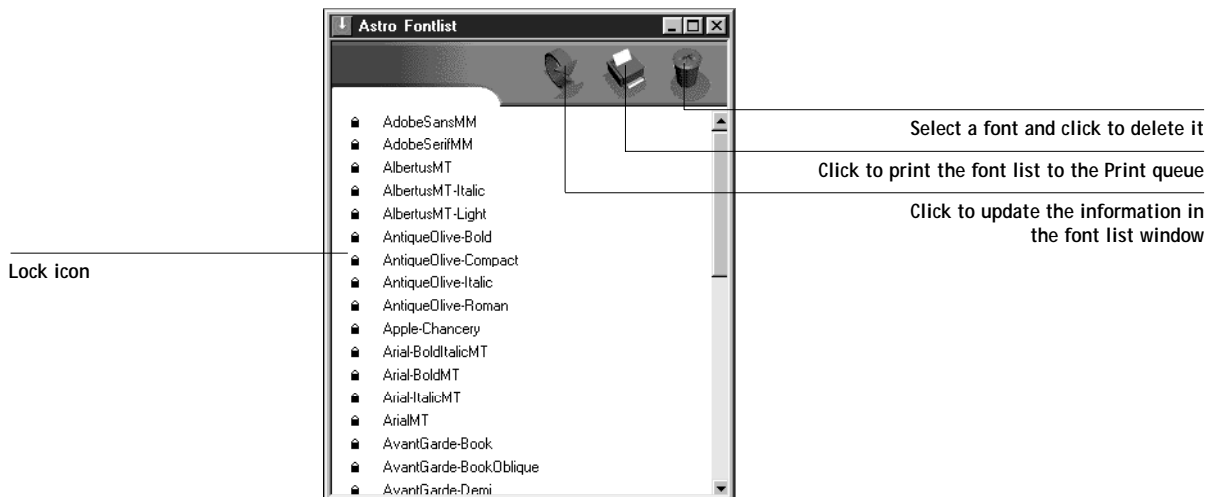

Chapter 6: Tracking and Managing Print Jobs

Fiery XJ user software includes a variety of tools that allow you to track and manage print jobs. The particular tools, and the access privileges for them, that are available to you depend on the conditions implemented by your site administrator. This chapter describes the functions of Fiery WebTools and Fiery utilities that let you track and manage jobs sent to the Fiery XJ.

Tools for job tracking and management

Depending on the workstation you use and the setup at your site, you may be able to choose between several Fiery XJ job tracking and management tools.

Fiery WebTools

If your site administrator has enabled Web Services on the Fiery XJ, you can access Fiery WebTools from Windows 95 and Windows NT 4.0 computers with an Internet browser. Fiery WebTools that provide *job tracking* capabilities are Fiery WebSpooler and the Status WebTool. Fiery WebSpooler also provides *job management* capabilities, provided you have the necessary access privileges (see page 6-2). For specific information on the browsers supported with Fiery WebTools, see *Getting Started*.

Fiery Spooler

Fiery Spooler, like Fiery WebSpooler, provides *job tracking and job management* capabilities. Fiery Spooler can be installed from the User Software CD on Windows 95, Windows NT 4.0, and Mac OS computers, and requires only a network connection to the Fiery XJ. If your network administrator has not enabled Web Services on the Fiery XJ, or if you do not have the necessary system support to use Fiery WebTools, you may choose to use Fiery Spooler for job management. For information on the system and network requirements for the Windows and Mac OS versions of Fiery Spooler, see *Getting Started*.

NOTE: The interface of Fiery Spooler for Windows is virtually identical to that of Fiery WebSpooler; therefore, the descriptions of both are combined into one section beginning on page 6-5. The interface of Fiery Spooler for Mac OS is significantly different from that of Fiery WebSpooler; it is described in detail starting on page 6-19.

About Fiery WebTools

Fiery WebTools reside on the Fiery XJ but can be accessed over the network from Windows 95 and Windows NT 4.0 computers. The Fiery XJ has a home page from which remote users can select among the Fiery WebTools in order to view server functions, manipulate jobs, and download printer file installers. For specific information on the browsers supported with Fiery WebTools, see *Getting Started*.

The following Fiery WebTools can be accessed from the Fiery XJ home page.

WebTool:	Summary:	For more information:
Status	Shows you the jobs currently processing and printing.	See page 6-4
WebSpooler	Allows you to view, manipulate, reorder, reprint, and delete jobs currently spooling, processing, or printing on the Fiery XJ. Also allows you to view, print, and delete the Job Log. Most of these functions require an Administrator password, if one has been set.	See "Fiery WebSpooler and Fiery Spooler for Windows" on page 6-5
Installer	Allows you to download Fiery XJ printer file installers directly from the server.	See <i>Getting Started</i>

Access privileges

The Fiery XJ system allows the site administrator to choose and implement a level of access and control appropriate for your particular site. The levels of access allowed to remote users depend on whether the administrator has enabled use of the Fiery WebTools, and whether a password is required to use certain features of the Fiery WebTools.

The two possible levels of access to Fiery WebTools are Administrator and Guest. When an Administrator password has been specified, the access levels are as follows:

Access level:	Privileges and password requirements:
Administrator	Has full access to all Fiery WebTools and Fiery XJ Control Panel functions; Administrator password required
Guest	Can view job status, but cannot make changes to jobs or Setup, and cannot view the Job Log; no password required

TO ACCESS FIERY WEBTOOLS:

1. Start up your Internet browser application.
See *Getting Started* for information about supported platforms and browsers.
2. Enter the IP address or the DNS name of the Fiery XJ.
Check with the administrator for this information.
3. If the Log In dialog box appears, enter the password and click OK.

The Log In dialog box appears only if an Administrator password has been set.

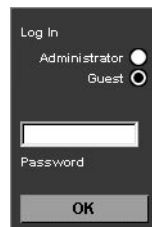

4. When the Fiery XJ home page appears, click to select one of the Fiery WebTools. Move the cursor over the buttons to display information about the selections.



NOTE: The Configure button appears only if you logged in as Administrator. With Administrator privileges, you can click this button and specify which of the Fiery WebTools are available to other users.

Checking Fiery XJ status with the Status WebTool

You can use the Status WebTool to see what jobs are currently processing and printing. The Status WebTool does not require any special access privileges. If the administrator has enabled Web Services in Setup and has provided you with the IP address of the Fiery XJ, you can use the Status WebTool to monitor the status of print jobs as they are rasterized and printed.

To access the Status WebTool, point your browser to the Fiery XJ home page and click Status. The current RIP Status and Printer Status appear in the window.



To open a new browser window for the Status display, click Float. You can then close other browser windows and leave the Status window open to continue checking the status of the Fiery XJ. As long as you keep the Status window open, it is dynamically updated.

To obtain more information about the status of jobs, use Fiery WebSpooler or Fiery Spooler.

Fiery WebSpooler and Fiery Spooler for Windows

Fiery WebSpooler and Fiery Spooler for Windows both provide a window on Fiery XJ and copier functions, and an interface from which you can control those functions.

NOTE: After launching, the Fiery WebSpooler and Fiery Spooler for Windows interfaces are virtually identical. Following the explanations of how to launch each tool, the remainder of this section uses the term “Fiery WebSpooler” to refer to *both* Fiery WebSpooler and Fiery Spooler for Windows. Where differences exist between the two, they are noted.

TO LAUNCH FIERY WEBSPOOLER:

1. From the Fiery XJ home page, click WebSpooler.
For instructions on how to access the Fiery XJ home page, see page 6-3.
2. To log in as Administrator, enter the Administrator password and click OK.
To log in as Guest, click OK, without entering any password.

The Fiery WebSpooler window appears in a new browser window.

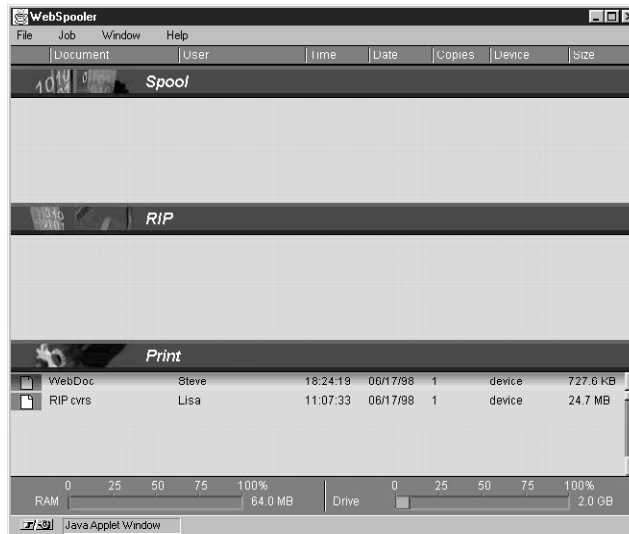

TO LAUNCH FIERY SPOOLER ON A WINDOWS COMPUTER:

1. Choose Fiery Spooler from the Start > Programs menu.
2. Select the Fiery XJ in the Chooser window that appears.
For information on setting up the connection to the Fiery XJ, see *Getting Started*.

6

6-7 Tracking and Managing Print Jobs

3. Click OK.

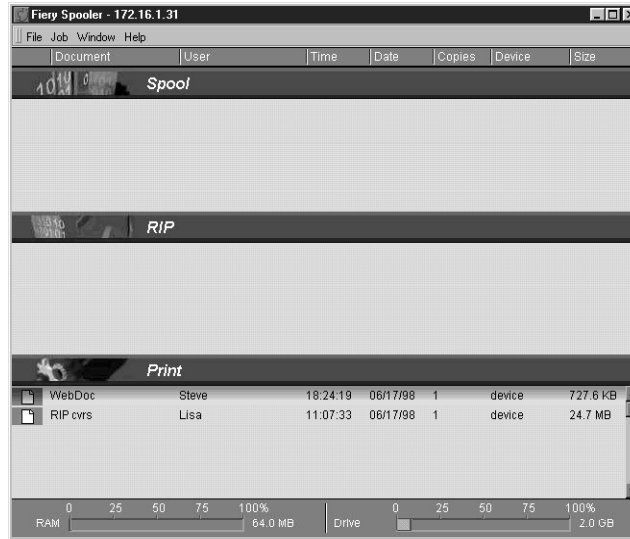

Job management features

Unless a password has been defined in Fiery XJ Setup, you can log in to Fiery WebSpooler without entering a password, and you are given full privileges which include:

- A view of current printing jobs and jobs stored on the Fiery XJ
- Control of printing jobs and a view of the Job Log
- Ability to clear the Job Log

After the Administrator has performed Setup and specified the password, user options depend on your login level. If you log in to Fiery WebSpooler as Guest, you have the first option only. If you log in as Administrator, you have all three options. For information about Setup and specifying passwords, see the *Administrator Guide*.

You can use Fiery WebSpooler to perform the following functions from your workstation:

- Override current job option settings
- Delete jobs
- Duplicate or rename jobs
- Change the priority of jobs
- Display, print, or delete the Job Log

Most of these functions require the Administrator password. However, even without a password, you can log in to Fiery WebSpooler as Guest with view-only privileges.

Job List window

Your first view of Fiery WebSpooler is the Job List window, which is divided into three areas by Spool, RIP, and Print status bars. The Job List window is surrounded by a frame that includes slider buttons and menus. System information indicators at the bottom of the window show the current availability of hard disk space and RAM on the currently selected Fiery XJ.

When the Fiery XJ is receiving and processing print jobs, the Job List window is a dynamic display, filled with the names of jobs and their characteristics. Status bars animate in real time as new jobs are processed and printed, and jobs move to different display areas.

6

6-9 Tracking and Managing Print Jobs

The screenshot shows the WebSpooler Job List window with the following sections:

- Menu bar:** File, Job, Window, Help
- Pool status bar:** Spool
- Spooled jobs:** (Empty area)
- RIP status bar:** RIP
- Rasterized (RIPped) jobs:** (Empty area)
- Print status bar:** Print
- Printed jobs:**

Document	User	Time	Date	Copies	Device	Size
WebDoc	Steve	18:24:19	06/17/98	1	device	727.6 KB
RIP cvs	Lisa	11:07:33	06/17/98	1	device	24.7 MB
- System information indicators:** RAM 64.0 MB, Drive 2.0 GB

The Spool, RIP, and Print areas of the Job List window represent the stages of printing a job. Jobs come in at the top level (Spool) and drop down to the Print level, unless they are held along the way.

- **Spooled jobs**—Jobs listed in the area below the Spool status bar area are PostScript files stored on the Fiery XJ disk. These jobs were sent to the Print queue. These PostScript files are saved on the server's hard disk. PostScript files can come in packets from the network, or from another place on the server hard disk. Jobs are added to a queue in the order in which they arrive, and they generally move to another queue in the same order unless someone has intervened to change the order.
- **RIPped jobs**—Jobs listed in the area below the RIP status bar are ready to print. They have already been rasterized (RIPped, or processed for printing) and are waiting, in order, for access to the printer. During RIPping, PostScript commands are interpreted in the Fiery XJ to allow the copier to print the file the way its originator intended.

The result of this interpretation is a *raster* file associated with the original PostScript file. In this raster file (raster image), color data is associated with each dot that can be rendered by the print engine. The color data tells the print engine whether or not to apply cyan, magenta, yellow, or black toner to each position on the page.

- **Printed jobs**—Jobs listed in the area below the Print status bar have already been printed. Printed jobs can be stored on the Fiery XJ disk. The number of jobs that can be stored (from 1 to 99) is defined in Setup.
- **Errors**—Jobs with an error are shown in red. To display the error, double-click the job line.

If you are logged in as Administrator, you can interact with a job in the window by selecting it and choosing a command from the Job menu, or by double clicking it and setting print option overrides. (However, if a password has been set and you are logged in as Guest, you can only view jobs; you cannot interact with them.)

The job icons displayed in the Fiery WebSpooler window are explained on page 6-12.

NOTE: If your job does not appear anywhere in the Fiery WebSpooler window, it may have already been printed; if so, it will appear in the Job Log. To view the Job Log, choose Show Job Log from the Window menu. (For more information on the Job Log, see page 6-16.)

Menu bar

The menu bar has four menus. When an action is not available in the current context, the command is dimmed.

Menu:	Choose this:	To do this:
File	Print Job Log	Print the Job Log
	Delete Job Log	Delete the Job Log
	Export Job Log	Save the Job Log as a text file
	Open Fiery	Launch Fiery WebSpooler for a different Fiery XJ
	Exit	Log out from the server and exit Fiery WebSpooler

Menu:	Choose this:	To do this:
Job (For more information on these commands, see page 6-14)	Delete Job(s)	Delete one or more selected jobs
	Duplicate Job(s)	Duplicate one or more selected PostScript data jobs in the Spool or Print areas
	Rename	Rename a selected job
	Print	Print the selected job(s); see page 6-13
	Process Next	Give top priority to this job
	Override Print Settings	View and edit print settings for the selected job(s); see page 6-15
Window	Show Job List	Show the Job List window
	Show Job Log	Show the Job Log window
Help	About	View the Fiery WebSpooler information screen

Status bars



Jobs actively involved in the three processes (spooling, rasterizing, and printing) are listed in the status bars that span the Job List window.

Status bars show the filename and user name for the active process, and an indication of its progress. Each status bar heads the list of jobs that have completed the process. Thus, beneath the Spool status bar, you see a list of spooled files; beneath the RIP status bar, you see a list of rasterized (RIPped) files. Beneath the Print status bar, you see a list of jobs that have already been printed.

NOTE: In the Spool status bar, the filename and user information always appear as “Unknown” (as shown below). This information is not available until the job has finished spooling to the Fiery XJ disk.

Job icons

There are two types of icons that are used for active jobs:

Icon:	Active jobs: (white icons)
 PostScript icon	PostScript data after printing, raster deleted
 Printer icon	PostScript or raster data headed for printing

Spool area

The job icon in the Spool area is described below:

Spool area icon:	What it indicates:	How long you see the job:
 White printer icon	PostScript data headed for Print	Until the RIP is free

The Spool area is the waiting area for jobs that will be RIPPed (jobs in the Spool queue).

Print queue jobs Network jobs sent to the Print queue appear in the Spool area where they are shown with a white printer icon. When they reach the head of the queue, they are RIPPed and printed.

Direct connection jobs Jobs printed to the Direct connection are not displayed in the Fiery WebSpooler job lists. They are displayed briefly in the status bars (where they cannot be selected) and are included in the Job Log.

RIP area

The job icon in the RIP area is described below:

RIP area icon:	What it indicates:	How long you see the job:
 White printer icon	Raster data headed for Print in its turn	Until copier is free to print the job

After a job is rasterized, it goes into the RIP area. The RIP area holds only raster data (i.e., jobs that have been rasterized). Jobs in the RIP area are waiting for the copier to be free.

NOTE: Raster jobs in the RIP area that are waiting to print cannot be manipulated by job commands.

Print area

The job icon in the Print area is described below:

Print area icon:	What it indicates:	How long you see the job:
 White PS icon	PostScript data only—raster data has been deleted	Until the job limit is reached

The Print area, also referred to as the Printed queue, contains jobs that have already been printed.

NOTE: A job row that appears in light red indicates that a PostScript error occurred while printing the job. To see the error, double-click anywhere in the row.

Newly printed jobs are added to the Printed queue, and are shown at the top of the list. Jobs are saved in the Printed queue until the job limit is reached. When the first job over the limit is printed, the oldest job is deleted from the disk. The default job limit is 10 jobs. The value for Jobs Saved in Printed Queue can be changed in Setup by the administrator.

NOTE: If you reprint a job in the Printed queue, the job returns to its original position in the Printed queue after it is printed.

While it is printing, a job consists of PostScript and raster data; jobs with only PostScript data remaining are represented by a white PS icon.

Job commands

Using the commands in the Job menu, you can alter the destinations, priorities and other characteristics of jobs that appear in the Fiery WebSpooler window.

Job commands are used to assign a selected job to a new destination or process. These commands are available from the Job menu (see page 6-10). The job commands available at a given time depend on the context; unavailable commands are dimmed.

The job commands available for selected jobs in the Job List window are listed in the following table.

Choose this:	To do this:
Delete Job(s)	Delete the job(s)
Duplicate Job(s)	Duplicate one or more selected PostScript data jobs in the Spool or Print areas. You can use the duplicate job(s) for different print options or a different destination. (The Duplicate command actually creates a reference to the original job, with the same name)
Rename	Rename the job (PostScript file)
Print	Print the job in its turn After printing, keep the printed job in the Print area until the job limit is reached.
Process Next	Give top priority to this job RIP (and then print) it as soon as the processor is free, before other waiting jobs Option is dimmed if there are no other waiting jobs

Choose this:	To do this:
Override Print Settings	View and override print settings for a selected job or a group of selected jobs

Overriding print settings

When logged in as Administrator, you can use the Override Print Settings command to check and override the print option settings (properties) of all jobs.

You can use this command for several purposes:

- To override a setting based on printed output or other print device conditions
- To change settings for a duplicate of the original job
- To print a single copy of a job before printing the number of copies required by the user

To change the print settings for a job, double-click the job line or select the job and choose Override Print Settings from the Job menu.

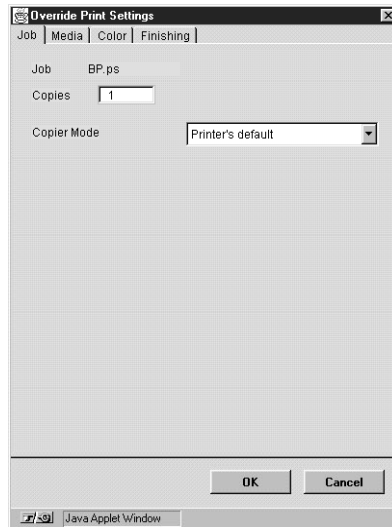

The options you set here are the same ones you set from the Print dialog box when you print from an application. For information about print options, see Appendix A, “Print Options.”

If you want to retain a copy of the job with its original settings, duplicate the job and rename the duplicate before you change any settings (see “Job commands” on page 6-14).

The Override Print Settings dialog box displays all the job settings encoded by the PostScript printer driver that can be decoded by the Fiery XJ. If you (as operator) have not changed anything, these are the settings a user entered before sending the job.

For information on print option settings, see Appendix A, “Print Options.”

Using the Job Log

From Fiery WebSpooler, you can view and print a log of all jobs printed by the Fiery XJ, including jobs downloaded with Fiery Downloader. You can also save the Job Log to a text file which you can then import into a spreadsheet or word processing application for job accounting purposes.

NOTE: If you logged in as Administrator, you can delete the Job Log from Fiery WebSpooler (see page 6-18). The Job Log is not available if you logged in as Guest.

TO DISPLAY, UPDATE, PRINT, DELETE, AND SAVE THE JOB LOG:

1. Choose Show Job Log from the Fiery WebSpooler Window menu.

6

6-17 Tracking and Managing Print Jobs

2. Click All or specify a date range.

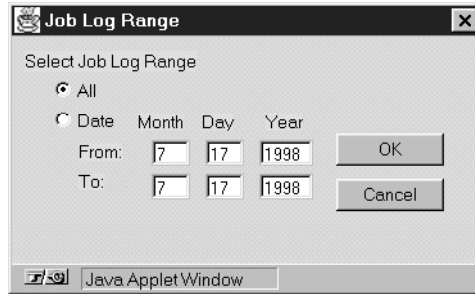

The dialog box is titled "Job Log Range" and contains the following elements:

- A label "Select Job Log Range".
- A radio button labeled "All" which is selected.
- A radio button labeled "Date".
- Input fields for "Month", "Day", and "Year" under the "Date" option, with values "7", "17", and "1998" respectively.
- Buttons for "OK" and "Cancel".
- A status bar at the bottom that says "Java Applet Window".

3. Click OK.

The Job Log appears in a new browser window.



The browser window is titled "WebSpooler - Astro" and has a menu bar with "File", "Job", "Page", "Window", and "Help". It displays a table of print jobs. On the right side of the window, there are three icons: a refresh icon, a printer icon, and a trash can icon. Lines connect these icons to labels "Update", "Print", and "Delete" respectively. The table has the following data:

Status	Document	User	Date	Start Time	End Time	Process Time	Size
OK	RIPcvs	Lisa	06/17/98	11:04:28	11:05:41	00:00:26	23.2
OK	WebDoc	Steve	06/17/98	18:24:23	18:25:15	00:00:03	727
OK	Configuration	Operator	06/17/98	18:28:22	18:29:00	00:00:02	8.5

The Job Log displays each job and the following information: status, document name, user name, date, start time, end time, process time, file size, device, paper size, media, number of originals, number of color pages, number of black-and-white pages, total number of pages, Note1, and Note2.

The Status column provides the following information about jobs:

OK	The job was printed normally.
ERROR	An error occurred during processing or printing.
CANCEL	The job was canceled before printing was completed.

4. To update the Job Log, click the Update button.
5. To print the Job Log, choose Print Job Log from the File menu or click the Print button.

The information displayed in the Job Log window prints to the current Fiery XJ. When you print the Job Log, totals are printed for all appropriate columns.

6. To clear the Job Log, choose Delete Job Log from the File menu or click the Delete button.

The system administrator can also print and clear the Job Log from the Control Panel.

Differences between Fiery WebSpooler and Fiery Spooler for Windows

Though the interfaces for both Fiery Spooler for Windows and Fiery WebSpooler are almost identical, there are some feature differences.

Connecting to a different Fiery XJ

With Fiery Spooler, you can connect to a different Fiery XJ from within the application using the following procedure.

TO CONNECT TO A DIFFERENT FIERY XJ:

1. Choose Open Fiery from the File menu.
2. Select the Fiery XJ in the Chooser window that appears.
For information on setting up the connection to the server, see *Getting Started*.
3. Click OK.
The Fiery Spooler main window appears.

Saving the Job Log as a file

With Fiery Spooler, you can save the Job Log as a file that you can view with a different application.

TO SAVE THE JOB LOG AS A FILE:

1. Choose **Export Job Log** from the **File** menu or click the **Export** button at the top of the **Job Log** window.

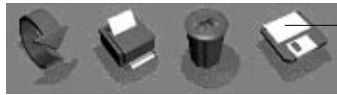

Export button

2. In the **File name** area, enter a name for the **Job Log** file (the default name is **Fiery Job Log.txt**).
3. Browse to the location where you want to save the file, and click **Save**.

The **Job Log** is saved as a text file, and the **Job Log** window reappears.

You can view the information in any application that can read a text file. Items are separated by tabs.

Fiery Spooler for Mac OS computers

For Mac OS computers, the Fiery Spooler interface and functionality differ from Fiery WebSpooler, and the Windows version of Fiery Spooler.

On a Mac OS computer, Fiery Spooler jobs can be in one of the following queues:

- | | |
|---------|---|
| Print | Normal print jobs sent to the Fiery XJ appear in the Print queue. You can move and manipulate these jobs as described below. |
| Printed | The jobs most recently sent to the Fiery XJ are saved in the Printed queue. You can drag these jobs back to the Print queue to print additional copies. The number of jobs saved in the Printed queue is set by your system administrator in Fiery XJ Setup . |

Jobs in the queues are stored on the Fiery XJ hard disk. Make sure that you leave enough space on the hard disk for fonts and other Fiery Spooler jobs.

You can use the Fiery Spooler Job Log to view information about jobs printed to the Fiery XJ for job accounting purposes, or saved for reference. The Job Log can be printed to the Fiery XJ or saved as a file and viewed in other applications.

TO LAUNCH FIERY SPOOLER ON A MAC OS COMPUTER:

1. Double-click the Fiery Spooler icon.
2. If your network is divided into zones, select the zone in which the Fiery XJ is located.
3. Select the Fiery XJ from the list of servers that appears, and click Connect.

The Fiery Spooler main window appears.

Server name or IP address of Fiery XJ	Astro_device																																																																																				
Current Print and RIP status	<p>Print Status: device : User: Steve ; Document: WebDoc</p> <p>Rip Status: User: Steve ; Document: WebDoc</p>																																																																																				
Name of the job currently printing	<table border="1"> <thead> <tr> <th>Document</th> <th>User</th> <th>Time</th> <th>Date</th> <th>Device</th> <th>Size</th> </tr> </thead> <tbody> <tr> <td colspan="6">Printing</td> </tr> <tr> <td>WebDoc</td> <td>Steve</td> <td>18:24:19</td> <td>06/17/98</td> <td>device</td> <td>745070</td> </tr> <tr> <td colspan="6">Waiting</td> </tr> <tr> <td>WebDoc</td> <td>Steve</td> <td>18:24:19</td> <td>06/17/98</td> <td>device</td> <td>745070</td> </tr> <tr> <td colspan="6">Ripping</td> </tr> <tr> <td>RIP ovr</td> <td>Lisa</td> <td>10:57:00</td> <td>06/17/98</td> <td>device</td> <td>24354057</td> </tr> <tr> <td colspan="6">Print</td> </tr> <tr> <td>RIP ovr</td> <td>Lisa</td> <td>10:57:00</td> <td>06/17/98</td> <td>device</td> <td>24354057</td> </tr> <tr> <td>WebDoc</td> <td>Steve</td> <td>20:05:55</td> <td>06/17/98</td> <td>device</td> <td>745070</td> </tr> <tr> <td colspan="6">Printed</td> </tr> <tr> <td>RIP ovr</td> <td>Lisa</td> <td>11:04:44</td> <td>06/17/98</td> <td>device</td> <td>25726233</td> </tr> <tr> <td>WebDoc</td> <td>Steve</td> <td>19:57:35</td> <td>06/17/98</td> <td>device</td> <td>745070</td> </tr> <tr> <td>WebDoc</td> <td>Steve</td> <td>19:57:35</td> <td>06/17/98</td> <td>device</td> <td>745070</td> </tr> </tbody> </table>	Document	User	Time	Date	Device	Size	Printing						WebDoc	Steve	18:24:19	06/17/98	device	745070	Waiting						WebDoc	Steve	18:24:19	06/17/98	device	745070	Ripping						RIP ovr	Lisa	10:57:00	06/17/98	device	24354057	Print						RIP ovr	Lisa	10:57:00	06/17/98	device	24354057	WebDoc	Steve	20:05:55	06/17/98	device	745070	Printed						RIP ovr	Lisa	11:04:44	06/17/98	device	25726233	WebDoc	Steve	19:57:35	06/17/98	device	745070	WebDoc	Steve	19:57:35	06/17/98	device	745070
Document	User	Time	Date	Device	Size																																																																																
Printing																																																																																					
WebDoc	Steve	18:24:19	06/17/98	device	745070																																																																																
Waiting																																																																																					
WebDoc	Steve	18:24:19	06/17/98	device	745070																																																																																
Ripping																																																																																					
RIP ovr	Lisa	10:57:00	06/17/98	device	24354057																																																																																
Print																																																																																					
RIP ovr	Lisa	10:57:00	06/17/98	device	24354057																																																																																
WebDoc	Steve	20:05:55	06/17/98	device	745070																																																																																
Printed																																																																																					
RIP ovr	Lisa	11:04:44	06/17/98	device	25726233																																																																																
WebDoc	Steve	19:57:35	06/17/98	device	745070																																																																																
WebDoc	Steve	19:57:35	06/17/98	device	745070																																																																																
Name of the job currently processing	RIP ovr																																																																																				
Scroll list of every document sent to the Print queue	<table border="1"> <thead> <tr> <th>Document</th> <th>User</th> <th>Time</th> <th>Date</th> <th>Device</th> <th>Size</th> </tr> </thead> <tbody> <tr> <td>RIP ovr</td> <td>Lisa</td> <td>11:04:44</td> <td>06/17/98</td> <td>device</td> <td>25726233</td> </tr> <tr> <td>WebDoc</td> <td>Steve</td> <td>19:57:35</td> <td>06/17/98</td> <td>device</td> <td>745070</td> </tr> <tr> <td>WebDoc</td> <td>Steve</td> <td>19:57:35</td> <td>06/17/98</td> <td>device</td> <td>745070</td> </tr> </tbody> </table>	Document	User	Time	Date	Device	Size	RIP ovr	Lisa	11:04:44	06/17/98	device	25726233	WebDoc	Steve	19:57:35	06/17/98	device	745070	WebDoc	Steve	19:57:35	06/17/98	device	745070																																																												
Document	User	Time	Date	Device	Size																																																																																
RIP ovr	Lisa	11:04:44	06/17/98	device	25726233																																																																																
WebDoc	Steve	19:57:35	06/17/98	device	745070																																																																																
WebDoc	Steve	19:57:35	06/17/98	device	745070																																																																																
Jobs with PostScript errors appear in Printed queue with Alert icon																																																																																					
Available space on Fiery XJ hard disk	Available Fiery Disk Space (MB): 3631																																																																																				

4. To access Administrator functions, choose Password from the Administrator menu. This menu is active only if a password was created on the Fiery XJ.

5. Enter the password in the window that appears, and click OK.



The job list

The job list includes information about the document name, user name, time and date sent, print device, and file size.

The window is split into regions that correspond to the different queues and steps in the printing process. You can click and drag a job to the Print region of the window to move it to the corresponding queue.

Buttons appear above the scroll list. The buttons are:



Update

Click to update the information in the Fiery Spooler main window.



Duplicate
and Print

Drag a document onto this button or select the document and click to duplicate it and put the duplicate in the Print queue.



Print

Drag a document onto this button or select the document and click to print it to the Print queue.



Hold







This queue is not enabled on the Fiery XJ. If you drag a document onto this button, or select the document and click this button, you will receive a Warning message.



Delete/
Cancel

Drag a document onto this button or select the document and click to delete it or cancel processing or printing it. You will be asked to verify that you want to delete the job. You can eliminate the verification notice by turning off the Confirm file deletion option in the Preferences dialog box.

The icons provide information about the job:

Printing		Printing icon	The job that is currently printing appears in this list; it can be selected and deleted to cancel printing.
Waiting		Printing icon	Jobs that have been processed and are waiting to print appear in this list, but they are dimmed because their settings cannot be changed and they cannot be moved or canceled.
Ripping		RIP icon	Jobs that are processing appear in this list; they can be selected and deleted to cancel processing.
Print		Print icon	Jobs that have not been processed appear in this list, in the order they will be processed and printed. The jobs can be selected and deleted to cancel processing and printing.
Printed		Printed icon	Jobs that have been printed are saved in this list. Jobs are stored in the Printed queue until the limit set by your system administrator in Fiery XJ Setup is reached. The jobs can be selected and deleted from the Fiery XJ hard disk.
Printed		Alert icon	If a PostScript error occurred while a job was printing, it appears in the Printed queue with an Alert icon (the Printed icon with a red slash) next to it. You can double-click the Alert icon to display the error message. The jobs can be selected and deleted from the Fiery XJ hard disk.

Choose Preferences from the Edit menu to configure how the Fiery XJ updates and deletes files.

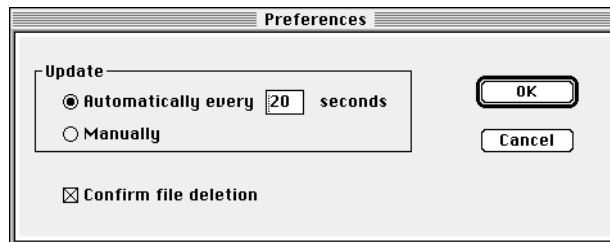

You can use this window to specify that the Fiery XJ:

Update Automatically every *n* seconds or **Update Manually**—This option lets you specify whether the Fiery Spooler main window is automatically updated every 20 seconds (or at an interval that you set), or whether it is updated only when you choose the Update command from the Window menu. By default, the Fiery Spooler main window is updated automatically every 20 seconds.

NOTE: When automatic updating is on, data is coming from the Fiery XJ across the network very frequently. This data adds to the network traffic, and may slow down other network jobs. For optimum network performance, turn off automatic updating in the Fiery Spooler Preferences dialog box; when you want to view updated information in the Fiery Spooler window, choose Update from the Window menu or click the Update button.

Confirm file deletion—Select this if you want a confirmation dialog box to appear before you delete a file.

Duplicating, copying, moving, and deleting jobs

Users are able to monitor their own print jobs. The Fiery XJ system administrator (or anyone with Fiery Spooler Password access) can move, delete, and configure jobs for all users, and can re-order jobs within a queue.

You can move your jobs from the Printed queue to the Print queue. By copying rather than moving a job, you leave a copy of the job in the Printed queue so that you can print the job again later. You can also duplicate a job if you want to have multiple copies of a job in the same queue.

Duplicating jobs

You can duplicate jobs in the Print and Printed queues:

- If you want to change printing parameters in the Override Print Settings dialog box without losing the original settings
- If you want to print more than 15 copies to the sorter (the maximum number of copies that you can print to the sorter is 15)

When you duplicate a job, the Fiery XJ creates a reference to the original file, so duplicate files do not require the full amount of disk space on the Fiery XJ. As long as one of the duplicates remain, the Fiery XJ saves the file, so you can delete all but one reference to a file.

TO DUPLICATE A JOB WITHIN A QUEUE:

1. Select the job that you want to copy by clicking its name.
The selected job is highlighted. If you want to select more than one job, shift-click to select multiple, adjacent jobs; control-command-click to select multiple, non-adjacent jobs.
2. Choose Duplicate Job(s) from the Edit menu.
The job appears at the bottom of the queue.

TO DUPLICATE AND PRINT A JOB:

1. Select the job that you want to copy by clicking its name.
The selected job is highlighted. If you want to select more than one job, shift-click to select multiple, adjacent jobs; control-command-click to select multiple, non-adjacent jobs.
2. Click the Duplicate and Print button, or drag the job to the Duplicate and Print button.
The job appears at the bottom of the Print queue.

TO COPY A JOB TO ANOTHER QUEUE:

1. Select the job that you want to copy by clicking its name.
The selected job is highlighted. If you want to select more than one job, shift-click to select multiple, adjacent jobs; control-command-click to select multiple, non-adjacent jobs.
2. Hold down the Option key as you drag the job to Print queue icon or to the Print section of the job list.
A copy of the job is moved to the Print queue, but the original job still appears in the Printed queue so that you can print the job at another time.

TO MOVE A JOB WITHIN A QUEUE:

1. Select the job that you want to move by clicking its name.
The selected job is highlighted. If you want to select more than one job, shift-click to select multiple, adjacent jobs; control-command-click to select multiple, non-adjacent jobs.
2. Drag the file to the new location in the queue.

TO DELETE A JOB FROM ANY OF THE QUEUES:

1. Select the job that you want to delete by clicking its name.
2. Drag the selected job to the Delete button or click the Delete button.
You can also choose Delete Job(s) from the Edit menu.
System administrators (or anyone with Fiery Spooler Password access) can delete any job.

Changing print settings for a job

You can set certain print settings for a job in the Override Print Settings dialog box. The settings in this dialog box override the settings in the Printer Specific Options dialog box and in Fiery XJ Setup.

You can change print settings only for jobs in the Print and Printed queues of the Fiery Spooler main window.

System administrators (or anyone with Fiery Spooler Password access) can change print settings for any job.

NOTE: The Override Print Settings dialog box may not reflect the entire set of print options that are available from the printer driver.

TO CHANGE PRINT SETTINGS FOR A JOB:

1. Double-click a job or select the job and choose Override Print Settings from the Edit menu.

The Override Print Settings dialog box appears.

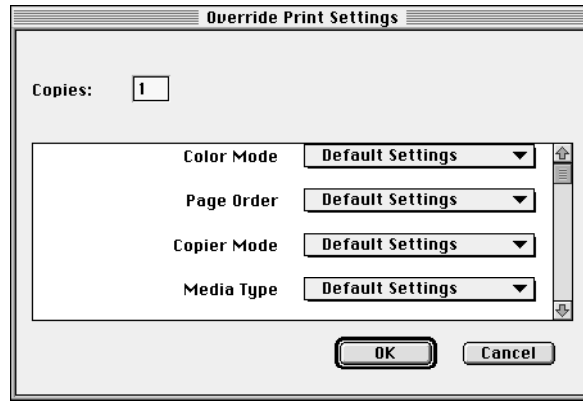

2. Choose the new settings from the pop-up menus.

If you leave a setting at Default Settings, the job will use the settings in the Printer Specific Options dialog box.

For information about these options, see Appendix A, “Print Options.”

3. Click OK to make changes.

Using the Job Log

With Fiery Spooler, you can view and print a log of all the jobs printed to the Fiery XJ. You can also save the Job Log as a text file that you can then import into a spreadsheet or word processing application for job accounting purposes. All jobs printed to the queues and printed by direct connection are listed in the Job Log.

TO DISPLAY, UPDATE, PRINT, SAVE, AND DELETE THE JOB LOG:

1. Choose Show Job Log from the Window menu.
2. Specify the period for the Job Log in the window that appears.

Click All to view all jobs since the Job Log was cleared; click Date if you want to specify a period of time for the Job Log.

3. Click OK.

The Job Log window displays a list of all the jobs and the following information about them: status, document name, user name, date, start time, end time, process time, file size, print device, paper size, media, number of originals, number of color pages, number of black and white pages, total number of pages, Notes 1, and Notes 2.

The information in the note fields is specified in the Print dialog box if you are using the AdobePS printer driver.

Use the scroll bar at the bottom of the window to view all fields in the Job Log window.

Status	Document	User	Date	Start Time	End Time	Process Time	Size	Device	P
OK	RIP ovrns	Lisa	06/17/98	11:04:28	11:05:41	00:00:28	24354172	device	
OK	Configuration	Operator	06/17/98	18:10:41	18:11:18	00:00:02	8678	device	
OK	WebDoc	Steve	06/17/98	18:24:23	18:25:15	00:00:03	745181	device	

The text in the Status column provides information about the job:

- OK The job was printed normally.
- ERROR A PostScript error occurred while a job was processing. You can double-click ERROR to display the error message. A dialog box displays the PostScript error. Click OK to close the dialog box.
- CANCEL The job was canceled before printing was completed.

4. To update the Job Log, click the Update button at the top of the window.
5. To print the Job Log, choose Print Job Log from the File menu or click the Print button at the top of the window.

The information displayed in the Job Log window prints to the current Fiery XJ. When you print the Job Log, totals are printed for all appropriate columns.

6. To save the Job Log as a file that you can view with a different application, choose Export Job Log from the File menu or click the Export button at the top of the window. Enter a name for the log file, and click Save.

The Job Log is saved as a text file, and the Job Log window reappears.

You can view the information in any application that can read a text file. Items are separated by tabs.

7. If you entered the Administrator password, you can choose Delete Job Log from the File menu to clear the Job Log.

The system administrator can also print and clear the Job Log from the Control Panel.

Chapter 7: Color Calibration

Calibrating the Fiery XJ ensures consistent, reliable color output. You can calibrate the Fiery XJ by using AutoCal from the Fiery XJ Control Panel. AutoCal allows you to obtain measurements from the copier and apply a calibration using the copier's built-in scanner.

Introduction

A calibration is generated from two components that originate separately: *measurements* and a *target*.

- Measurements represent the actual color behavior of the copier; they are computed from readings taken by the copier's scanner.
- Targets represent the goal of printing, such as obtaining pleasing color from the copier or simulating another print device. A copier-specific target is provided with the Fiery XJ.

Calibration generates curves describing various color densities based on a specified target and a set of measurements that you provide.

Once you have calibrated the Fiery XJ, a calibration is stored on the Fiery XJ; this calibration is referred to as the *resident calibration*. The resident calibration is applied to *all* print jobs.

NOTE: Changing the resident calibration has the potential to affect *all* jobs for *all* users, so you may want to limit the number of people authorized to perform calibration. An Administrator password can be set to control access to calibration from the Fiery XJ Control Panel.

Understanding calibration

The Fiery XJ allows you to choose between two standard calibrations. A standard calibration uses one of the targets provided with the Fiery XJ (r2 or Linear) with a new set of measurements.

Calibration allows you to:

- Maximize the color reproduction capabilities of the Fiery XJ
- Ensure consistent color quality across time
- Produce consistent output across Fiery XJ servers of the same engine
- Optimize the Fiery XJ for using ColorWise Color Rendering Dictionaries (CRDs) and CMYK simulations, and for using ICC-compatible profiles when printing RGB color data
- Linearize the Fiery XJ while maintaining the currently available density range

How calibration works

Success in obtaining satisfactory print quality from a digital color printer depends on many factors. Among the most important are establishing and maintaining optimal toner densities. Density is a measure of the light absorbed by a surface. By carefully regulating toner densities, you can obtain consistent printed color.

Even with a calibrated system, toner density is affected by such variables as room humidity and service settings; it also tends to drift over time. Regular measurement detects day-to-day variations in densities, and calibration corrects for them.

Calibration works by creating calibration curves on the Fiery XJ that compensate for the difference between actual and desired density values.

Calibration curves and target curves are the graphic equivalent of transfer functions, which are mathematical descriptions of changes that will be made to the data with which you start. Transfer functions are often graphed as Input/Output curves.

Target curves (targets, for short) result from applying one or more transfer functions in sequence. The server generates calibration curves after comparing measured values to the final target values for each of the four toner colors.

Measurements

Measurements files contain numerical values that correspond to the toner density produced by the copier when it prints solid cyan, magenta, yellow, and black, and graduated tints of those colors.

To create a measurements file, you first print a page of color patches from the Control Panel. Then you measure the patches, using the copier's scanner. The new measurements are automatically downloaded to the Fiery XJ.

You can print a calibration Comparison Page showing the result of using the new measurements with any of the current targets. When you are satisfied with a particular combination of measurements and target, you apply the calibration to the Fiery XJ; this becomes the new resident calibration.

Targets

Target files define desired calibration results. Two target files are provided with the Fiery XJ. When you calibrate the Fiery XJ, you can select the target file that corresponds to the typical printing goals at your site. This becomes the resident calibration target that is used by default.

The calibration targets provided with the Fiery XJ are:

- r2—Optimized for best results with the copier.
- Linear—Results in output that divides the maximum measured density for each color into equal density steps to provide an even distribution of tones over the copier's density range. When you linearize the printer, the entire measured density range in each color channel is divided into equal steps. Equal steps in toner percentage, such as 0%, 10%, and 20%, are printed in equal steps in density, and appear as roughly equal visual steps. This gives a linear response using the range of densities available.

Scheduling calibration

In general, you should calibrate the Fiery XJ at least once a day, depending on the volume of print jobs. If it is very important to maintain consistent colors, or if the copier is subject to wide fluctuations in temperature or humidity, calibrate every few hours. Calibrate when you change paper stock. In general, to get the best performance from the copier, calibrate whenever there is a noticeable change in print quality.

If you need to split a print job into two or more batches, it is especially important to calibrate before printing each batch.

You should also calibrate the Fiery XJ system after copier maintenance. However, because the copier may be less stable immediately after maintenance, wait until you have printed approximately 50 pages before you calibrate.

NOTE: Output from the copier is very sensitive to changes in temperature and humidity. To minimize these effects, the copier should not be installed near a window or in direct sunlight, or near a heater or air conditioner. Paper is sensitive to climate changes as well, and should be stored in a cool, stable environment.

The copier has a self-calibration feature (Auto Color Calibration, or ACC) that optimizes toner densities after scanning a test print on the copier glass. If you never calibrate the Fiery XJ from the Control Panel, the self-calibration feature can improve the color output of print jobs. Using the copier's self-calibration feature alone will not necessarily bring output densities from the copier to the optimal values for Fiery XJ printing. However, if you regularly calibrate the Fiery XJ, your print jobs can sometimes be improved by asking a service technician to disable the copier's self-calibration feature.

The copier allows you to adjust printed color from its touch panel display. You can typically increase or decrease toner density for one or all toner colors. These control panel settings affect copies made from the copier glass, and may affect Fiery XJ output as well. If they do, make sure these settings remain the same (preferably at a neutral position) prior to calibration, and from one print job to the next. If you change these settings, calibrate the Fiery XJ when you have finished changing settings.

Print some standard color pages. Images with skin tones offer a very good basis for comparison. You can save and compare pages you printed at different times. If there is a noticeable change in appearance, you should calibrate or linearize the Fiery XJ system.

If the solid density patches (100% cyan, magenta, yellow or black) look less saturated with time, show the pages to the copier technician to find out whether adjusting the copier can improve the output.

Checking calibration status

You can check whether the Fiery XJ is calibrated, what target was used, and when the printer was last calibrated. You can view information about the last calibration by printing a Configuration page or Test Page from the Control Panel.

Calibrating with AutoCal from the Control Panel

You can calibrate the Fiery XJ from the Control Panel using AutoCal, which calibrates the Fiery XJ using the copier's built-in scanner as a densitometer. If an Administrator password has been set, you will need it for calibration.

For instructions on using the Fiery XJ Control Panel, and for more details on the AutoCal options, see the *Administrator Guide*.

For information on error messages you may see during the AutoCal procedure, see “AutoCal error messages” on page C-9.

NOTE: You will need the Kodak Gray Scale strip that came in the media pack with your Fiery XJ.

TO ACCESS AND USE AUTOCAL:

1. Reboot the Fiery XJ, and be ready to press a button at the Control Panel shortly after startup diagnostics.
2. Press any key when the Fiery XJ message “For software update or setup, press any key.” appears.
3. Choose Run Setup.
4. Choose Calibration, and choose Set Up Calibration.
5. For Tray, choose the paper source for the patch page.
6. Choose Calibrate.
The Select Target screen appears.
7. Select the target.

8. When prompted, select Yes to print the measurement page.

This page is comprised of swatches of color that will be measured by the copier and then compared to the target color values.

After the page is printed, the Measure Page screen is displayed.

NOTE: The measurement page printed from the Control Panel is printed in the copier's Photo mode (for Photo mode calibration). If you want to print a measurement page in the copier's Letter mode (for Letter mode calibration), download the file "Letter.ps" from the User Software CD. This file is located in the Color\Calib folder (Windows) or the Color:Calibration folder (Mac OS).

9. Select Yes in the Measure Page screen.
10. When prompted on the Control Panel, place the Kodak Gray Scale strip face down along the top of the copier glass.

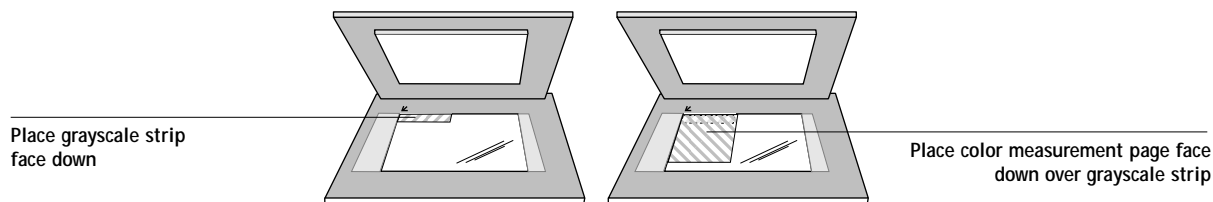

11. Place the color measurement page face down over the grayscale strip.
Align the top-left corners of the grayscale strip and the color measurement page with the arrow at the top-left corner of the copier glass.
Make sure the patches on the grayscale strip do not overlap the color patches.
12. Close the copier lid, being careful not to move the grayscale strip and color measurement page.
13. Click OK.
Status messages display the progress of scanning and calculating measurements.
14. When prompted to Print Comparison Page, select Yes.
This page provides you with a preview of the selected calibration.
15. When prompted to overwrite calibration, select Yes.

16. Select Yes to confirm.
Status messages display progress information. The new calibration becomes the resident calibration.
17. When calibration is complete, choose Exit Calibration.
This automatically restarts the Fiery XJ.

Removing calibration

It is also possible to remove calibration from the Fiery XJ. In general, it is not necessary because any new calibration replaces the existing one.

TO REMOVE CALIBRATION FROM THE CONTROL PANEL:

1. From the Control Panel, access the Calibration menu as described on page 7-5.
2. Choose Remove Calibration.
3. When prompted, verify that you want to proceed with removing calibration.
The current calibration curves are removed, and a default calibration is restored.

Working with simulations

Simulations, or *press simulations*, allow you to use the copier as a proofing device for jobs that will print on an offset press. Because the range of colors available on the copier is different from that of a press, the Fiery XJ automatically adjusts the color so that the output falls within the range of colors a press can produce.

Three simulation target files are provided with the Fiery XJ user software. These files enable you to load targets for the following press standards:

- DIC—Japanese press standard
- Euroscale—European press standard
- SWOP-Coated—US press standard

Changing simulation targets

By default, the Fiery XJ is loaded with the SWOP-Coated simulation target. You can change the simulation target by downloading special files from the User Software CD to the Fiery XJ.

NOTE: Changing the simulation target on the Fiery XJ also resets the default Rendering Style setting to Presentation.

TO CHANGE THE SIMULATION TARGET:

1. Insert the User Software CD into your computer.
2. Launch Fiery Downloader.
3. For Windows, browse to the Color\Simulate file.

For Mac OS, browse to the Color:Simulation file.
4. For Windows, select the Dic.ps file to load the DIC simulation; select the Eurosc1.ps file to load the Euroscale simulation; or select the Swop.ps file to load the SWOP-Coated simulation.

For Mac OS, select the Dic.ps file to load the DIC simulation; select the Euroscale.ps file to load the Euroscale simulation; or select the Swop.ps file to load the SWOP-Coated simulation.
5. Click Download to download the file to the Fiery XJ.
6. Reboot the Fiery XJ by powering it off and on.

The simulation target you just loaded remains the Fiery XJ default simulation until it is changed again.
7. If necessary, change the default Rendering Style setting on the Fiery XJ.

Appendix A: Print Options

Print options give you access to the special features of the copier and the Fiery XJ. Print options can be specified in several places—in Fiery XJ Setup from the Control Panel, from the printing application, from Fiery Downloader, and from Fiery WebSpooler or Fiery Spooler. The table in this appendix briefly describes each print option, gives its default setting, and provides information on any constraints or requirements in effect.

Where to set print options

- During Fiery XJ Setup (from the Control Panel)

Some settings are specified during Setup by the administrator. To see the current default settings, print the Configuration page from the Fiery XJ Control Panel.

- From applications

With the Adobe PostScript printer drivers (included in your user software) and the Microsoft PostScript printer driver for Windows NT 4.0, you can specify and override job settings when you print a job. See Chapter 2, “Printing from Windows Computers” and Chapter 3, “Printing from Mac OS Computers” for information about specifying job settings from applications.

- From Fiery Downloader

Only one setting—Copies—can be specified when printing jobs with Fiery Downloader. To change the Copies setting in Fiery Downloader, select the job in the Files to be Downloaded (Windows) or Files to Download (Mac OS) list and click Options. For more information, see Chapter 5, “Downloading Files and Fonts”.

- Overrides from Fiery WebSpooler or Fiery Spooler

To change job settings from Fiery WebSpooler or Fiery Spooler, double-click a job to display the Override Print Settings dialog box. For more information, see Chapter 6, “Tracking and Managing Print Jobs.”



Print options and override hierarchy

In the following table, underlined settings in the “Option and settings” column may indicate either default printer driver settings (PPD defaults), or that a default has been specified in Fiery XJ Setup. To find out about the current Setup defaults, print the Configuration page from the Fiery XJ Control Panel.

The override hierarchy is as follows:

- A user’s printer driver settings override the Fiery XJ Setup settings.
- Settings made from Fiery WebSpooler or Fiery Spooler override the user’s printer driver settings.

Option and settings: (Default setting is underlined)	Description:	Requirements, constraints, and information:
Color Mode <u>Printer’s default</u> /CMYK/Grayscale	Specify the color mode for the current print job. Select CMYK for a full-color document. Select Grayscale for a grayscale or black-and-white document.	The default setting for printing reflects the Color Mode setting specified in Fiery XJ PS Setup.
Copier Mode <u>Printer’s default</u> /Photo/Letter	Select Photo if the file is a photograph. Select Letter if the file contains detailed drawings and small text.	
Copies <u>1</u> - 999	Specify the number of copies of the job to print.	
Media Type <u>Plain Paper</u> /Thick Paper/Transparency	Select Plain Paper if you will be printing on standard bond copier paper. Select Thick Paper if you will be printing on heavy paper stock. Select Transparency if you will be printing on a transparency.	For more information, see page A-3.
Notes 1 and Notes 2	Use one or both of these fields to enter special information about the job.	The Notes 1 and Notes 2 fields each have a 32-character limit.
Page Order <u>Printer’s default</u> /Forward/Reverse	Select Forward to print the pages of your job from first to last. Select Reverse to print the pages of your job from last to first.	The default setting for printing reflects the Page Order setting specified in Fiery XJ PS Setup.

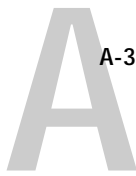

Option and settings: (Default setting is underlined)	Description:	Requirements, constraints, and information:
Rendering Style <u>Printer's default</u> /Photographic/ Presentation/Solid Color	Specify a default color rendering dictionary (CRD) to be used when you print RGB images, objects, and text.	The default setting for printing reflects the Rendering Style setting specified in Fiery XJ Color Setup. For more information, see page A-3.
Sorter Mode Printer's default/Off/ <u>Collate</u> /Sort	Specify how to output multiple-page/ multiple-copy jobs.	For more information, see page A-4.

More information about print options

The following sections provide additional information about print options. See the table above for information on the settings, requirements, and constraints in effect for these options.

Media Type

The Media Type option allows you to select the type of media for loading into the bypass tray.

Plain Paper—Standard bond paper. Check your copier manual for specific information.

Thick Paper—Heavy paper. Check your copier manual for specific information.

Transparency—Transparency sheets.

Rendering Style

Use this option to select a default color rendering dictionary (CRD) to be used when you print RGB images, objects, and text.

Photographic—Optimizes the range of colors on the Fiery XJ to produce the best results for photographic or bitmapped images.

Presentation—Optimizes the output of pure, saturated colors such as those used in business presentations.

Solid Color—Most useful for printing spot colors such as those found in company logos or corporate charts and graphs.

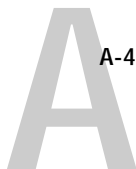

Sorter Mode

Off—Disables the sorter.

Collate—Copies of a complete job are collated and output into the bottom tray.

Sort—Copies of a complete job are sorted and output into one of 15 bins, arranged in page order.

Appendix B: Font List

This appendix lists the built-in printer fonts included with your Fiery XJ.

Printer fonts

Listed below are the 136 built-in printer fonts on the Fiery XJ.

In addition to the fonts listed below, two Adobe Multiple Master fonts are included and are used for font substitution in PDF files.

NOTE: For Mac OS computers, install the corresponding screen fonts from the User Software CD. For instructions, see *Getting Started*.

Adobe Type 1 fonts

The Fiery XJ includes 117 Adobe Type 1 fonts:

- The Mac OS column lists the name as it appears on the Font menu on a Mac OS computer. For example, in most applications, to use “Bodoni-Bold,” choose Bodoni Bold from the Font menu.
- The Windows menu name is the name as it appears on the Font menu on a Windows computer. The style refers to the style that must be selected in the application to access the particular PostScript font. For example, to use “Bodoni-Bold,” choose Bodoni from the Font menu and Bold from the Style menu.

PostScript name:	Mac OS menu name:	Windows menu name, style:
AlbertusMT-Light	Albertus MT Lt	Albertus MT Lt
AlbertusMT	Albertus MT	Albertus MT
AlbertusMT-Italic	Albertus MT It	Albertus MT, Italic
AntiqueOlive-Roman	Antique Olive Roman	Antique Olive Roman
AntiqueOlive-Bold	Antique Olive Bold	Antique Olive Roman, Bold
AntiqueOlive-Italic	Antique Olive Italic	Antique Olive Roman, Italic
AntiqueOlive-Compact	Antique Olive Compact	Antique Olive Compact
AvantGarde-Book	Avant Garde	AvantGarde
AvantGarde-Demi	Avant Garde Demi	AvantGarde, Bold
AvantGarde-BookOblique	Avant Garde BookOblique	AvantGarde, Italic



PostScript name:	Mac OS menu name:	Windows menu name, style:
AvantGarde-DemiOblique	Avant Garde DemiOblique	AvantGarde, Bold Italic
Bodoni	Bodoni	Bodoni
Bodoni-Bold	Bodoni Bold	Bodoni, Bold
Bodoni-Italic	Bodoni Italic	Bodoni, Italic
Bodoni-BoldItalic	Bodoni BoldItalic	Bodoni, Bold Italic
Bodoni-Poster	Bodoni Poster	Bodoni Poster
Bodoni-PosterCompressed	Bodoni PosterCompressed	Bodoni PosterCompressed
Bookman-Light	Bookman	Bookman
Bookman-Demi	Bookman Demi	Bookman, Bold
Bookman-LightItalic	Bookman LightItalic	Bookman, Italic
Bookman-DemiItalic	Bookman DemiItalic	Bookman, Bold Italic
Carta	Carta	Carta
Clarendon-Light	Clarendon Light	Clarendon Light
Clarendon	Clarendon	Clarendon
Clarendon-Bold	Clarendon Bold	Clarendon, Bold
CooperBlack	Cooper Black	Cooper Black
CooperBlack-Italic	Cooper Black Italic	Cooper Black, Italic
Copperplate-ThirtyThreeBC	Copperplate33bc	Copperplate33bc
Copperplate-ThirtyTwoBC	Copperplate32bc	Copperplate32bc
Coronet	Coronet	Coronet
Courier	Courier	Courier
Courier-Bold	Courier Bold	Courier, Bold
Courier-Oblique	Courier Oblique	Courier, Italic
Courier-BoldOblique	Courier BoldOblique	Courier, Bold Italic
Eurostile	Eurostile	Eurostile
Eurostile-Bold	Eurostile Bold	Eurostile Bold
Eurostile-ExtendedTwo	Eurostile ExtendedTwo	Eurostile ExtendedTwo
Eurostile-BoldExtendedTwo	Eurostile BoldExtendedTwo	Eurostile ExtendedTwo, Bold
GillSans	GillSans	GillSans
GillSans-Bold	GillSans Bold	GillSans, Bold
GillSans-Italic	GillSans Italic	GillSans, Italic
GillSans-BoldItalic	GillSans BoldItalic	GillSans, Bold Italic
GillSans-Light	GillSans Light	GillSans Light
GillSans-LightItalic	GillSans LightItalic	GillSans Light, Italic

B

B-3 Font List

PostScript name:	Mac OS menu name:	Windows menu name, style:
GillSans-Condensed	GillSans Condensed	GillSans Condensed
GillSans-BoldCondensed	GillSans BoldCondensed	GillSans Condensed, Bold
GillSans-ExtraBold	GillSans ExtraBold	GillSans ExtraBold
Goudy	Goudy	Goudy
Goudy-Bold	Goudy Bold	Goudy, Bold
Goudy-Italic	Goudy Italic	Goudy, Italic
Goudy-BoldItalic	Goudy BoldItalic	Goudy, Bold Italic
Goudy-ExtraBold	Goudy ExtraBold	Goudy ExtraBold
Helvetica	Helvetica	Helvetica
Helvetica-Bold	Helvetica Bold	Helvetica, Bold
Helvetica-Oblique	Helvetica Oblique	Helvetica, Italic
Helvetica-BoldOblique	Helvetica BoldOblique	Helvetica, Bold Italic
Helvetica-Narrow	Helvetica Narrow	Helvetica-Narrow
Helvetica-Narrow-Bold	Helvetica Narrow Bold	Helvetica-Narrow, Bold
Helvetica-Narrow-Oblique	Helvetica Narrow Oblique	Helvetica-Narrow, Italic
Helvetica-Narrow-BoldOblique	Helvetica Narrow BoldObl	Helvetica-Narrow, Bold Italic
Helvetica-Condensed	Helvetica Condensed	Helvetica Condensed
Helvetica-Condensed-Bold	Helvetica CondensedBold	Helvetica Condensed, Bold
Helvetica-Condensed-Oblique	Helvetica CondensedOblique	Helvetica Condensed, Italic
Helvetica-Condensed-BoldObl	Helvetica CondensedBoldObl	Helvetica Condensed, Bold Italic
JoannaMT	Joanna MT	Joanna MT
JoannaMT-Bold	Joanna MT Bd	Joanna MT, Bold
JoannaMT-Italic	Joanna MT It	Joanna MT, Italic
JoannaMT-BoldItalic	Joanna MT Bd It	Joanna MT, Bold Italic
LetterGothic	Letter Gothic	Letter Gothic
LetterGothic-Bold	Letter Gothic Bold	Letter Gothic, Bold
LetterGothic-Slanted	Letter Gothic Slanted	Letter Gothic, Italic
LetterGothic-BoldSlanted	Letter Gothic BoldSlanted	Letter Gothic, Bold Italic
LubalinGraph-Book	Lubalin Graph	LubalinGraph
LubalinGraph-Demi	Lubalin Graph Demi	LubalinGraph, Bold
LubalinGraph-BookOblique	Lubalin Graph BookOblique	LubalinGraph, Italic
LubalinGraph-DemiOblique	Lubalin Graph DemiOblique	LubalinGraph, Bold Italic
Marigold	Marigold	Marigold
MonaLisa-Recut	Mona Lisa Recut	Mona Lisa Recut

PostScript name:	Mac OS menu name:	Windows menu name, style:
NewCenturySchlbk-Roman	New Century Schlbk	NewCenturySchlbk
NewCenturySchlbk-Bold	New Century Schlbk Bold	NewCenturySchlbk, Bold
NewCenturySchlbk-Italic	New Century Schlbk Italic	NewCenturySchlbk, Italic
NewCenturySchlbk-BoldItalic	New Century Schlbk BoldIt	NewCenturySchlbk, Bold Italic
Optima	Optima	Optima
Optima-Bold	Optima Bold	Optima, Bold
Optima-Italic	Optima Italic	Optima, Italic
Optima-BoldItalic	Optima BoldItalic	Optima, Bold Italic
Oxford	Oxford	Oxford
Palatino-Roman	Palatino	Palatino
Palatino-Bold	Palatino Bold	Palatino, Bold
Palatino-Italic	Palatino Italic	Palatino, Italic
Palatino-BoldItalic	Palatino BoldItalic	Palatino, Bold Italic
StempelGaramond-Roman	StempelGaramond Roman	StempelGaramond Roman
StempelGaramond-Bold	StempelGaramond Bold	StempelGaramond Roman, Bold
StempelGaramond-Italic	StempelGaramond Italic	StempelGaramond Roman, Italic
StempelGaramond-BoldItalic	StempelGaramond BoldItalic	StempelGaramond Roman, Bold Italic
Symbol	Symbol	Symbol
Tekton	Tekton	Tekton
Times-Roman	Times	Times
Times-Bold	Times Bold	Times, Bold
Times-Italic	Times Italic	Times, Italic
Times-BoldItalic	Times BoldItalic	Times, Bold Italic
Univers-Extended	Univers Extended	Univers Extended
Univers-BoldExt	Univers BoldExt	Univers Extended, Bold
Univers-ExtendedObl	Univers ExtendedObl	Univers Extended, Italic
Univers-BoldExtObl	Univers BoldExtObl	Univers Extended, Bold Italic
Univers-Light	Univers 45 Light	Univers 45 Light
Univers-Bold	Univers 65 Bold	Univers 45 Light, Bold
Univers-LightOblique	Univers 45 LightOblique	Univers 45 Light, Italic
Univers-BoldOblique	Univers 65 BoldOblique	Univers 45 Light, Bold Italic
Univers	Univers 55	Univers 55
Univers-Oblique	Univers 55 Oblique	Univers 55, Italic

PostScript name:	Mac OS menu name:	Windows menu name, style:
Univers-CondensedBold	Univers 67 CondensedBold	Univers 47 CondensedLight, Bold
Univers-CondensedBoldOblique	Univers 67 CondensedBoldObl	Univers 47 CondensedLight, Bold Italic
Univers-Condensed	Univers 57 Condensed	Univers 57 Condensed
Univers-CondensedOblique	Univers 57 CondensedOblique	Univers 57 Condensed, Italic
ZapfChancery-MediumItalic	Zapf Chancery	ZapfChancery
ZapfDingbats	Zapf Dingbats	ZapfDingbats

TrueType fonts

The Fiery XJ includes 19 TrueType fonts:

PostScript name:	Mac OS menu name:	Windows menu name, style:
Apple-Chancery	Apple Chancery	Apple Chancery
Arial-BoldItalicMT	Arial Bold Italic	Arial, Bold Italic
Arial-BoldMT	Arial Bold	Arial, Bold
Arial-ItalicMT	Arial Italic	Arial, Italic
ArialMT	Arial	Arial
Chicago	Chicago	Chicago
Geneva	Geneva	Geneva
HoeflerText-Black	Hoefler Text Black	Hoefler Text Black
HoeflerText-BlackItalic	Hoefler Text Black	Hoefler Text Black, Italic
HoeflerText-Italic	Hoefler Text	Hoefler Text, Italic
HoeflerText-Ornaments	Hoefler Text Ornaments	Hoefler Text Ornaments
HoeflerText-Regular	Hoefler Text	Hoefler Text
Monaco	Monaco	Monaco
New York	New York	New York
TimesNewRomanPS-BoldMT	Times New Roman Bold	Times New Roman, Bold
TimesNewRomanPS-BoldItalicMT	Times New Roman Bold Italic	Times New Roman, Bold Italic
TimesNewRomanPS-ItalicMT	Times New Roman Italic	Times New Roman, Italic
TimesNewRomanPSMT	Times New Roman	Times New Roman
Wingdings-Regular	Wingdings	Wingdings

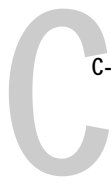

Appendix C: Troubleshooting

This appendix provides a list of error messages that may appear on the Fiery XJ Control Panel, as well as troubleshooting tips.

Error messages

Error messages can result from problems with the print job, the Fiery XJ, or the copier. Some of the most common error conditions are listed here.

Following are the messages (listed in alphabetical order), with the appropriate corrective action for each one. You can cancel the pending print job while you attend to the error condition. A few normal status messages are included in this list in case they cause concern.

Fiery XJ message:	Corrective action/additional information:
Busy	The Fiery XJ has received a print job, but the copier is being used to make a copy. This message appears when someone makes a copy without first selecting Suspend Printing from the Functions menu. The Fiery XJ will begin the print job when the copy job is finished.
Check power & cable	There is a problem with the copier power or cable connection. First check to make sure that the copier is turned on. There may also be a problem with the cable connection between the Fiery XJ and the copier. Make sure that the cable has not come loose. The Fiery XJ will resume printing when the cable is securely connected to both the Fiery XJ and the copier.
Close Bypass Tray	The bypass tray is open. The Fiery XJ will resume printing when the bypass tray is closed.
Communication error	There is a communication error between the copier and the Fiery XJ. Check the cable connections and the copier's user interface for additional information.
Copier offline	Someone has selected Suspend Printing from the Functions menu on the Fiery XJ Control Panel. When you select Resume Printing on the Control Panel, printing will resume normally.
Door open	One of the copier doors is open. The Fiery XJ will resume printing when the door is closed.

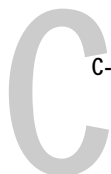

Fiery XJ message:	Corrective action/additional information:
Error-check panel	There is an unidentified problem with the copier. Check the copier user interface for additional messages. The copier will resume printing when the problem is corrected.
Load ____ in any tray	The copier is not loaded with the paper size specified. The Fiery XJ will resume printing when the copier is loaded with the required paper.
Load ____ in bypass tray	The copier's bypass tray is not loaded with the paper size specified. The Fiery XJ will resume printing when the bypass tray is loaded with the required paper.
Load ____ thick in bypass tray	The bypass tray is not loaded with the thick paper specified. The Fiery XJ will resume printing when you have loaded the required thick paper into the bypass tray.
Load ____ trans in bypass tray	The bypass tray is not loaded with the transparencies specified. The Fiery XJ will resume printing when you have loaded the required transparencies into the bypass tray.
Load ____ tray 1	The copier's Tray 1 is not loaded with the paper size or type specified. The Fiery XJ will resume printing when Tray 1 is loaded with the required paper.
Load ____ tray 2	The copier's Tray 2 is not loaded with the paper size or type specified. The Fiery XJ will resume printing when Tray 2 is loaded with the required paper.
Load ____ tray 3	The copier's Tray 3 is not loaded with the paper size or type specified. The Fiery XJ will resume printing when Tray 3 is loaded with the required paper.
No black toner	The black (K) toner has run out. Replenish the black toner container according to the instructions in your copier manual.
No cyan toner	The cyan (C) toner has run out. Replenish the cyan toner container according to the instructions in your copier manual.
No fuser oil	The fuser oil bottle in the fixing assembly is empty. Replace the fuser oil according to the instructions in your copier manual. The Fiery XJ will resume printing when you have replaced the fuser oil.
No magenta toner	The magenta (M) toner has run out. Replenish the magenta toner container according to the instructions in your copier manual.

Fiery XJ message:	Corrective action/additional information:
No yellow toner	The yellow (Y) toner has run out. Replenish the yellow toner container according to the instructions in your copier manual.
Paper jam	There is a paper jam in the copier. Open the copier doors and check the locations indicated on the copier display. The Fiery XJ will resume printing when you have cleared the paper jam and closed the copier doors.
Sorter limit ____	The sorter unit has one bottom output tray and 15 output bins; therefore, the maximum number of copies that can be sorted is 15. Sending 16 or more copies to the sorter results in the excess copies of the job being discarded. In order to print and sort more than 15 copies you can resend the job, 15 copies at a time, from the Print dialog box, from Fiery WebSpooler, or from Fiery Spooler.
Unknown error	An error occurred with the copier. Check the copier user interface for more information.
Warming up	The copier is powering up. It will be ready for printing in a few minutes.
Waste toner full	The copier's waste toner container is full. The Fiery XJ will resume printing when you empty or replace the container.

Maintaining optimal system performance

The Fiery XJ does not require maintenance. Beyond the routine requirements of servicing and maintaining the copier and replenishing consumables there are a few things you can do to improve the overall performance of your system:

- Reduce unnecessary two-way communication.

If users notice that the server is frequently too busy to receive jobs, it may be because several users are running utilities that are updated often. Large numbers of remote users running Fiery Downloader or Fiery WebTools may have a significant effect on Fiery XJ performance.
- Schedule the printing workload by checking job ticket information before printing. Print jobs with the same output and paper specifications together to minimize paper changes. Also, print routine jobs while you prepare to print jobs with special instructions or special media.

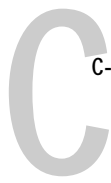

- Avoid printing with the server “Disk full” warning.

If you see this warning, delete jobs that have been held for a long time and are not likely to be needed. Avoid this condition by deleting old jobs on a regular basis. The date associated with a job is the original date it was sent.

Even when the disk is full, some disk space is reserved for printing a tabloid size job, but printing proceeds only when the oldest printed job is deleted from the Printed queue (Print area).

Troubleshooting

In case of problems, and before you call for service, check the guidelines in this section. If you are unable to resolve the problem, make a note of the error condition and contact your authorized service/support center.

This section provides some troubleshooting guidelines should a problem arise. If you are unable to resolve a problem after referring to this section, contact your site administrator.

General printing problems

If this happens:	Try this:
You cannot select or view one of the queues.	<ul style="list-style-type: none">• Have your system administrator enable the queue in Setup on the Fiery XJ Control Panel.
Printing ties up your computer for too long.	<ul style="list-style-type: none">• Print to the Print queue instead of to the Direct connection. When you print to the Print queue, the job is stored on the Fiery XJ until it can be processed and printed; when you print to the Direct connection, the job cannot be sent to the Fiery XJ until the previous job is finished processing, so you must wait longer to use your computer.
Special paper or transparency options are dimmed.	<ul style="list-style-type: none">• Select a Paper Source that supports the media type you are using.

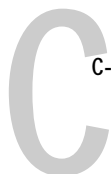

If this happens:	Try this:
<p>Message requests a paper size that you don't have.</p>	<ul style="list-style-type: none">• Cancel the job and do one of the following: If you are printing a PostScript file, ask the administrator to set the Convert Paper Sizes setting in PS Setup to convert the job to a paper size you do have. You can do this to convert between US and metric paper sizes. If you are printing a file from an application, change the page size in the Page Setup dialog box.
<p>You cannot print with QuarkXPress 3.32 using the AdobePS 8.5.1 driver on a Mac OS computer.</p>	<ul style="list-style-type: none">• Remove the file called Balloon Help from your QuarkXPress application folder and relaunch QuarkXPress.
<p>Fiery XJ doesn't respond to a Print command.</p>	<ul style="list-style-type: none">• Has someone disconnected the copier by selecting Suspend Printing from the Functions menu? If someone has selected Suspend Printing on the Fiery XJ Control Panel to interrupt printing (to make a color copy, for example), your print job will not resume until someone selects Resume Printing from the Functions menu on the Control Panel.• Did you select the Fiery XJ as the current printer? Before printing, you must select the Fiery XJ as the current printer from your Mac OS, Windows, or UNIX workstation.• Make sure that the copier is switched on. Someone may have turned the copier off, or the Automatic Power-Off or Power Saver mode function may have engaged. Even with the copier off, the Fiery XJ appears in the Chooser as long as the Fiery XJ itself is turned on.• If you are printing over an IPX (Novell) network, verify through the PCONSOLE utility that the job was sent to the Novell queue and that the queue is being used by the Fiery XJ.• Make sure that the job does not contain a PostScript error. Use Fiery WebSpooler (or Fiery Spooler) to check the job's status. A job containing a PostScript error appears in red in the Fiery WebSpooler display.

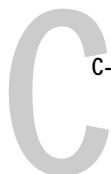

If this happens:	Try this:
Jobs sent to the parallel port do not print.	<ul style="list-style-type: none">• Review the procedures provided in <i>Getting Started</i> on how to prepare the Fiery XJ and your Windows 95 computer for parallel port printing. Also see your Windows 95 documentation.• Ask the administrator to increase the parallel "Port Timeout in Seconds" on the Fiery XJ Control Panel.• Ask the administrator to change the Ignore EOF Character setting on the Fiery XJ Control Panel. If you will be printing ASCII format PostScript only, set Ignore EOF Character to No; if you will be printing Binary format PostScript, set it to Yes.• If you print using the DOS copy command, make sure to use the /b option when printing binary files.• If the PostScript printer driver that you are using lets you select bidirectional communication, make sure that it is disabled. This is generally set from the Properties dialog box for the printer.

Problems with print quality

If this happens:	Try this:
Print settings for your job output do not match the settings you gave.	<ul style="list-style-type: none">• Make sure that you did not override the setting for the job in another place. For information about options and overrides, see Appendix A "Print Options."
You get poor printing results.	<ul style="list-style-type: none">• Does your application require one of Fiery XJ printer description files? If you are printing from an application such as Adobe Separator or PageMaker, MacroMedia FreeHand, or QuarkXPress, make sure that the Fiery XJ printer description file is installed correctly. For information about installing these files, see <i>Getting Started</i>.• Make sure the system has been calibrated.
The registration or colors of an image are not what you expected.	<ul style="list-style-type: none">• Print a test page or make a test copy with the copier. The problem may be with the copier. If your test page or copy show that the copier is working properly, correct the problem within your application software. If the test page or copy are wrong, your copier may need to be calibrated or adjusted in some other way.

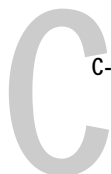

If this happens:	Try this:
Color output is incorrect.	<ul style="list-style-type: none">• Check with the administrator about the current calibration information. The copier may need to be recalibrated because it has been too long since it was calibrated or because it is using a different target.• Check with the administrator about the current simulation target loaded on the Fiery XJ. For more information, see “Working with simulations” on page C-7.
Color file prints in black and white.	<ul style="list-style-type: none">• In the Print Options dialog box, make sure that Color/Grayscale or ColorSync Color Matching or PostScript Color Matching is selected (not Black and White).• Make sure that the Color Mode selected for the job is CMYK and not Grayscale.
Desktop Color Separations (DCS) format images print incorrectly.	<ul style="list-style-type: none">• Make sure that you selected the correct options to send separations in the application's Print dialog box.• Make sure that you have the file for every layer of separation that you are printing.
QuickDraw fill patterns print as solids.	<ul style="list-style-type: none">• Use the Adobe PostScript Printer driver (or the Apple LaserWriter 8.3 or later printer driver).

Problems with Fiery Downloader

If this happens:	Try this:
General problems	<ul style="list-style-type: none">• Make sure that you are using the latest version. If you are updating your Fiery XJ to new system software, delete the previous versions of Fiery Downloader from your Mac OS or Windows computer and install the latest versions to insure full compatibility.• Make sure <i>either</i> the NET_WIPX.DLL file (for IPX/SPX networks) <i>or</i> the NET_WSCK.DLL file (for TCP/IP networks) is in the WINDOWS\SYSTEM directory. Only <i>one</i> of these files should be in the WINDOWS\SYSTEM directory and it must be the correct file for your system.• Make sure that the NET_WSCK.INI file is in the WINDOWS directory.• Open the NET_WSCK.INI file in a text editor and make sure that it is customized correctly for your site; or, throw away the NET_WSCK.INI file and configure the Chooser list again. For more information, see <i>Getting Started</i>.

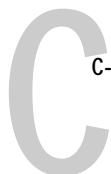

If this happens:	Try this:
<p>You cannot connect to the Fiery XJ from Fiery Downloader.</p>	<ul style="list-style-type: none">• Make sure that the Fiery XJ is not being calibrated. If the Fiery XJ is being calibrated, you cannot connect to it. This insures that only one person is calibrating the server at any time and that print jobs do not use unexpected calibration.• If you are using Windows 95 or Windows NT, verify that the .DLL file in your Windows\System folder is the correct one for the network protocol you are using. For IPX networks, the correct file is NET_WIPX.DLL. For TCP/IP networks, the correct file is NET_WSCK.DLL. Only <i>one</i> of these files should be in the Windows\System folder.• Make sure your NET_WSCK.INI file is set up correctly. This file must be set up for Windows 95 and Windows NT printing with TCP/IP and IPX/SPX. For instructions, see <i>Getting Started</i>.
<p>You cannot print an EPS file using Fiery Downloader.</p>	<ul style="list-style-type: none">• Try printing using the “Showpage” option in the Download PostScript File dialog box. The Showpage (after EPS files) option adds a showpage PostScript language command at the end of the print job. Certain applications omit this necessary PostScript language command when they generate EPS files. You will need to select the Append Showpage option when printing EPS files generated by these applications. If you continue having difficulties printing an EPS file with Fiery Downloader, try printing the file from the application in which it was created.• Make sure that the job does not contain a PostScript error. Use Fiery WebSpooler to check the job’s status. A job containing a PostScript error appears in red in the Fiery WebSpooler display.
<p>You have problems downloading a font with Fiery Downloader.</p>	<ul style="list-style-type: none">• Check with the administrator to make sure that the Direct connection is enabled. The Direct connection must be used to download fonts. (Files can be downloaded via the Print queue.)
<p>Extra blank page prints after a Fiery Downloader job.</p>	<ul style="list-style-type: none">• Turn off the “Showpage (after EPS file)” option. This option adds a special PostScript command that will cause an extra blank page to print if it is not needed.

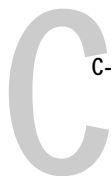

Problems with Fiery WebTools

If this happens:	Try this:
General problems	<ul style="list-style-type: none">• Clear the cache (Netscape Communicator) or history (Microsoft Internet Explorer).

Setup error messages

For information on Setup error messages, see the *Administrator Guide*.

AutoCal error messages

AutoCal error messages can result from problems during the AutoCal procedure.

Fiery XJ message:	Additional information:
Error 5	The calibration file cannot be opened.
Error 6	The calibration file was not read correctly.
Error 8	The measurement page did not scan properly, either because it is crooked or the data is corrupted.
Error 11	The color strips on the measurement page are inconsistent.
Error 12	The copier model being used is not supported.
Error 20	The measurement page cannot be scanned because the dots per inch (dpi) are incorrect.
Error 102	The grayscale strip is crooked or is positioned incorrectly.
Error 103	The grayscale strip is positioned too far to the left or to the right of the measurement page.
Error 104	The grayscale strip is positioned too far above the measurement page.
Error 111	The grayscale strip could not be found; either reposition the strip correctly or position it vertically.

Index

A

- access
 - levels xv, 6-2
 - restricting xv, 6-4
- Administrator password xv, 1-5, 6-3, 6-4
- Alert Status screen 1-2
- AppleTalk 3-2
- AutoCal calibration 7-5, 7-6

B

- Brightness option 5-5
- broken LCD 1-7
- buttons, Control Panel 1-2

C

- calibration
 - checking status 7-5
 - current 7-1
 - from the Control Panel 7-1, 7-5, 7-6
 - measurements 7-1, 7-2, 7-3
 - overview 7-1, 7-2
 - resident 7-1
 - scheduling 7-3
 - self-calibration 7-4
 - targets 7-1, 7-2
- Calibration option 1-6
- calibration patch page 7-3
- cancel command (UNIX) 4-3
- Cancel Job
 - from the Control Panel during printing 1-3
 - from the Control Panel during RIPping 1-3
- Change (Administrator) Password option 1-6
- Chooser list (Windows) C-7
- Clear Server command 1-6
- color, troubleshooting output C-7

- Color Mode option A-2
- Color Setup option 1-6
- Comparison Page
 - calibration 7-3
- Configuration page 7-5
 - printing from the Control Panel 1-4
- Configure button
 - Fiery WebTools 6-4
- Confirm file deletion option 6-23
- Control Panel 1-1 to 1-7
 - activity light 1-1, 1-3
 - buttons 1-2
 - calibration from 7-1
 - down button 1-2
 - Functions menu 1-4
 - line selection buttons 1-2
 - Menu button 1-2
 - removing calibration 7-7
 - status screens 1-2
 - up button 1-2
- Control Panel, printer settings overridden 2-7
- Control Panel map
 - printing from the Control Panel 1-4
- copier, adjusting printed color from 7-4
- Copier Mode option A-2
- Copies option A-2

D

- DCS (Desktop Color Separations) files
 - default settings, *see* printer default settings
- Delete command 6-11, 6-14
- Delete Job Log command 6-10
- densitometer
 - for calibration 7-5
- density patches 7-4
- Desktop Color Separations, *see* DCS
- DIC simulation 7-7

- differences
 - between Fiery Spooler for Windows and Fiery WebSpooler 6-18
 - Direct connection xvi, 5-5, 6-12
 - not in Chooser, Mac OS 3-1
 - required to download fonts 5-6, C-8
 - disk space used 6-8
 - display window 1-2
 - documentation xii
 - down button 1-2
 - Downloader, *see* Fiery Downloader
 - Duplicate command 6-11
- E**
- EPS (Encapsulated PostScript) files
 - downloading from Mac OS 3-4
 - downloading from Windows 2-8
 - EPS files C-8
 - downloading 2-1
 - error messages during Setup C-9
 - Euroscale simulation 7-7
 - Exit command 6-10
 - Exit Setup option 1-6
- F**
- Fiery Downloader 5-1 to 5-8
 - choosing a printer 5-3
 - Connection Type option 5-5
 - Copies option 5-5
 - downloading files or fonts 5-3 to 5-6
 - Download Progress bar 5-2
 - Font List option 5-3
 - Hard Disk area 5-2
 - Mac OS 3-4
 - printing from 5-3
 - Print Status area 5-2
 - restriction with parallel port 2-8
 - RIP Status area 5-2
 - troubleshooting C-7 to C-8
 - using from remote workstation 5-1
 - Windows 2-8
 - Fiery Spooler
 - changing print settings 6-25
 - deleting jobs 6-25
 - duplicating jobs 6-24
 - overriding user job settings A-1
 - Fiery Spooler, overriding Printer Setup 2-4, 2-7
 - Fiery WebSpooler
 - accessing 6-6
 - Guest (view-only) privileges 6-8
 - Job menu 6-14
 - overview 6-2
 - status bars 6-8
 - Fiery WebTools
 - accessing xvi, 6-3, 6-5
 - Configure button 6-4
 - home page 6-4
 - Installer 6-2
 - passwords 6-2
 - problems with C-9
 - Status 6-2, 6-4, 6-5
 - WebSpooler 2-4, 2-7, 6-2, A-1
 - File menu commands 6-10
 - File port, saving files to 2-8
 - font list
 - displaying 5-2
 - printing 5-2
 - Font List option (Fiery Downloader) 5-3
 - fonts
 - Adobe Type 1 5-6, 5-7, B-1
 - downloading and managing 5-1, 5-5, 5-6, 5-7
 - list, displaying 5-8
 - locked 5-8
 - PostScript B-1
 - printer fonts 5-7
 - printer fonts on server 1-4
 - printing font list 1-4
 - screen fonts (Mac OS) 5-7
 - TrueType 5-6, B-5

Font Substitution Table 5-6
 Functions menu, Control Panel 1-3, 1-4

G

Guest access xv, 6-3, 6-7

H

held jobs 6-13
 Help menu commands 6-11

I

icons
 Print area 6-13
 RIP area 6-13
 Spool area 6-12
 Info Status screen 1-3
 Installer WebTool, *see* Fiery WebTools

J

job
 areas 6-9
 defined xiii
 deleting 6-14
 deleting in Fiery Spooler 6-25
 duplicating 6-24
 limit 6-13
 overrides 6-15
 job icons 6-10
 Print area 6-13
 RIP area 6-13
 Spool area 6-12
 Job Log
 displaying 6-16
 printing from the Control Panel 1-4
 using (from Fiery Spooler) 6-26
 using (from Fiery WebSpooler) 6-16
 viewing printed jobs 6-10
 Job Log Setup option 1-6
 Job menu commands 6-11, 6-14
 job overrides
 Color Mode option A-2
 Copier Mode option A-2

Media Type option A-3
 Page Order option A-2
 Rendering Style option A-3
 Sorter Mode option A-3, A-4

job settings, *see* print options
 Jobs Saved in Printed Queue 6-13

L

LCD 1-1, 1-7
 line selection buttons 1-2
 lock icon 5-8
 lp command 4-2
 lpq command 4-1, 4-2, 4-3
 lpr command 4-1
 lprm command 4-1, 4-3

M

Mac OS
 Paper Source menu 3-3
 PostScript printer setup 3-2
 printer default settings 3-3
 Printer Specific Options menu 3-3
 printing 3-1 to 3-4
 printing with Fiery Downloader 5-1 to 5-8
 tray selection 3-3
 measurements file 7-2, 7-3
 Media Type option A-2, A-3
 Menu button 1-2
 messages, *see* error messages

N

NET_WIPX.DLL C-7, C-8
 Network Setup option 1-6
 NET_WSCK.DLL C-7, C-8
 NET_WSCK.INI C-7, C-8
 Notes fields A-2
 in Job Log 6-27
 Mac OS 3-3
 Windows 95 2-5

O

- on/off switch 1-5
- Override Print Settings command 6-11, 6-15, 6-25

P

- Page Order option A-2
- paper, sizes supported xiv
- Paper Source menu
 - Mac OS 3-3
 - Windows 95 2-3
 - Windows NT 4.0 2-7
- parallel port
 - printing problems C-6
 - printing with 2-8
- passwords
 - Administrator 6-3
 - Change (Administrator) Password option 1-6
 - for calibration 7-1
- performance, optimizing C-3
- permissions xv
- Photographic rendering style option A-3
- Plain Paper option A-3
- PostScript xiii, 6-9
 - downloading files from Mac OS 3-4
 - downloading files from Windows 2-8
 - downloading files with Fiery Downloader 5-1
 - error 6-13
 - icon 6-12
 - printing files from UNIX 4-1
 - RIP xiii
- PostScript printer description files, *see* PPD files
- PostScript printer drivers xiv
 - Mac OS 3-1
 - Windows 95 2-1
- PostScript printer setup
 - Mac OS 3-2
- PostScript Setup option, *see* PS Setup option

- power switch 1-5
- PPD (PostScript Printer Description) files xiii, xiv
 - defaults A-2
- PPDs 2-1, 3-1
- Presentation rendering style option A-3
- press simulations, *see* simulations
- Print area 6-9
 - icons 6-13
- Print command 6-11, 6-14
- Print command (Windows) 2-1
- Printed queue 6-10, 6-13, 6-19
- printer (job) icon 6-12
- printer default settings xvi, A-1 to A-4
 - Mac OS 3-3
 - Windows 95 2-4
- printer driver, *see* PostScript printer drivers
- printer settings, customizing 6-11
- printer setup
 - settings 2-7
 - with Adobe PostScript Printer Driver for Windows 95 2-2 to 2-5
 - with Microsoft PostScript Printer Driver for Windows NT 4.0 2-6
- Printer Setup option 1-6
- Printer Specific Options menu 3-3
- printing
 - Configuration page 1-4
 - defined xiii
 - font list 1-4, 5-2
 - from Fiery Downloader 5-1 to 5-8
 - from Mac OS applications 3-1 to 3-4
 - server information pages 1-4
 - to local port 2-8
 - troubleshooting C-4 to C-8
 - UNIX workstations 4-1 to 4-3
 - Windows 95 2-1
 - Windows NT 4.0 2-6
 - with parallel port 2-8
- printing connections on the network xvi
- Print Job Log command 6-10

print jobs
 deleting from queue 6-11

print options A-1 to A-4
 settings 2-5
 specific to color server 2-4, 2-7
 Windows 95 2-2 to 2-5
see also printer default settings

Print Pages command 1-4
 Control Panel 1-4

Print queue xvi, 5-5, 6-19
 not in Chooser, Mac OS 3-1

Print Status screen 1-3

Process Next command 6-11, 6-14

PS Setup option 1-6

Q

QuarkXPress, printing problems C-5

queues 6-9
 queues, access to xvi

Queues window
 spooled jobs 6-9

R

RAM
 in use 6-8
 total 6-8

raster
 data 6-13, 6-14
 icon 6-12

rasterizing, *see* RIPping

Reboot Server command, from Control Panel 1-4

remote access 5-1

Rename command 6-11, 6-14

Rendering Style option A-3

resident calibration 7-1

resolutions supported xiv

restricting access to server xv

Resume Printing command
 Control Panel 1-4

RIP, defined xiii

RIP area 6-9, 6-13

RIPped jobs 6-9

RIPping

RIP Status screen 1-3

Run Diagnostics command 1-4

S

safety 1-7

server
 cleaning 1-7
 display window 1-7
 restarting 1-6
 shutting down 1-7

Server Setup option 1-6

'showpage' after EPS files option 5-5

simulations
 overview 7-7

Solaris 2 4-3

Solid Color rendering style option A-3

Sorter Mode option A-3, A-4

spool, defined xiii

Spool area 6-9
 job icons 6-12

spooled jobs 6-9
 displayed in Fiery WebSpooler 6-10
 icons 6-12

Spooler, *see* Fiery Spooler

starting the server 1-5

status bars 6-8, 6-11
 Print 6-8
 RIP 6-8
 Spool 6-8

status screens, Control Panel 1-2

Status WebTool, *see* Fiery WebTools

SunOS 4 4-3

Suspend Printing command
 from Control Panel 1-4

SWOP-Coated simulation 7-7

T

- target curve, *see* targets
- targets 7-2
 - copier target 7-3
 - Linear 7-3
 - provided with the color server 7-3
 - see also* calibration *and* simulations
- TCP/IP printing 4-1
- Test Page 7-5
 - printing from Control Panel 1-4
- Thick Paper option A-3
- transfer functions 7-2
- Transparency option A-3
- tray selection
 - Mac OS 3-3
 - Windows 95 2-3
 - Windows NT 4.0 2-7
- troubleshooting C-4
 - color output C-7
 - Fiery Downloader C-7 to C-8
 - general printing problems C-4 to C-6
 - problems with print quality C-6 to C-7

U

UNIX

- BSD (Berkeley Software Distribution)
 - variant of 4-3
 - displaying jobs in queue with 4-2
 - printing from 4-1 to 4-3
 - removing jobs from queue with 4-3
 - System V 4-3
- up button 1-2
- user software xvi

W

- warning
 - display window breakage 1-7
- WebSpooler
 - overriding user job settings A-1
- WebSpooler, *see* Fiery WebTools
- Windows 95
 - Notes fields 2-5
 - Paper Source menu 2-3
 - PostScript printer driver 2-1
 - printer default settings 2-4
 - printing with 2-1
 - tray selection 2-3
- Windows NT 4.0
 - Paper Source menu 2-7
 - printing with 2-6
 - tray selection 2-7